



INSTALLATION AND OPERATING INSTRUCTIONS

Humidification system
TurboFogNeo 1, 2, 2x1, 2x2, 8
NanoFogEvolution/Sens
DI Flex / DI Flex 2

Thank you for choosing Condair

Installation date (DD/MM/YYYY):

Commissioning date (DD/MM/YYYY):

Installation site:

Model:

Serial number:

Proprietary rights

This document and the information disclosed herein are proprietary data of Condair Group AG. This instruction manual (including extracts thereof) may not be reproduced or passed on, nor may the contents thereof be used by or passed on to any third party without the written permission of Condair Group AG. Any infringements are punishable and entail a liability for damages.

Liability

Condair Group AG is not liable for any damages incurred as a result of poorly executed installation, improper operation or the use of components or equipment not approved by Condair Group AG.

Copyright notice

© Condair Group AG, all rights reserved

Subject to technical alterations

Contents

1	Introduction	5
1.1	First things first!	5
1.2	Notes on the installation and operating instructions	5
2	For your safety	8
2.1	Intended use	8
2.2	General safety notices	8
3	Product overview	10
3.1	Functional description	10
3.2	Equipment overview	11
3.3	Equipment structure	13
3.3.1	TurboFogNeo 1, 2, 2x1 and 2x2	13
3.3.2	TurboFogNeo 8	14
3.3.3	NanoFogEvolution / NanoFogSens	15
3.3.4	DI Flex 2 M – MK / DI Flex 2 L – MK	16
3.3.5	DI Flex M – MK / DI Flex L – MK	17
3.4	High-pressure nozzles	18
3.4.1	Design	18
3.4.2	Properties	18
4	Installation overview	20
4.1	TurboFogNeo / NanoFog	20
4.2	DI Flex / DI Flex 2	21
5	Mounting the nebulizers	22
5.1	General information on positioning	22
5.2	Mounting the TurboFogNeo 1, 2, 2x1, 2x2	23
5.2.1	Positioning the TurboFogNeo 1, 2, 2x1, 2x2	23
5.2.2	Mounting the TurboFogNeo 1 and 2	24
5.2.3	Mounting the TurboFogNeo 2x1 and 2x2	24
5.3	Mounting the TurboFogNeo 8	25
5.3.1	Additional information on positioning the TurboFogNeo 8	25
5.3.2	Positioning the TurboFogNeo 8	25
5.3.3	Mounting the TurboFogNeo 8	26
5.4	Mounting the NanoFogEvolution / NanoFogSens	27
5.4.1	Additional information on positioning the NanoFogEvolution / NanoFogSens	27
5.4.2	Positioning the NanoFogEvolution / NanoFogSens	27
5.4.3	Mounting the NanoFogEvolution / NanoFogSens	28
5.5	Mounting the DI Flex 2	29
5.5.1	Additional information on positioning the DI Flex 2	29
5.5.2	Positioning the DI Flex 2	29
5.5.3	Mounting the DI Flex 2	30
5.6	Mounting the DI Flex	31
5.6.1	Additional information on positioning the DI Flex	31
5.6.2	Positioning the DI Flex	31
5.6.3	Mounting the DI Flex	32

6	Hydraulic connection of the nebulizers	33
6.1	Installing the high-pressure hose	33
6.2	General information	33
6.3	Compressing the high-pressure hoses	34
7	Electrical connection of the nebulizers	35
7.1	General connection instructions	35
7.2	Determination of the maximum number of nebulizers per power supply device	36
7.3	Connection TurboFogNeo 1, 2, 2x1, 2x2	37
7.4	Connection TurboFogNeo 8	38
7.5	Connection NanoFogEvolution / NanoFogSens	39
7.6	Connection DI-Flex / DI-Flex 2	40
8	Maintenance	41
8.1	Check	41
8.2	Maintenance	42
8.3	Replacement of nozzles	42
8.4	Replacing the nebulizers	43
9	Troubleshooting	44
9.1	Error list	44
10	Technical data	46
10.1	Technical data TurboFogNeo 1, 2, 2x1 and 2x2 nebulizer	46
10.2	Technical data NanoFogEvolution/Sens nebulizer	47
10.3	Technical data TurboFogNeo 8 nebulizer	47
10.4	Technical data DI Flex / DI Flex 2 nebulizer	48
10.5	Technical data HumPower II control unit	49
10.6	Technical data transformer	49
11	Electrical cable specifications	50
11.1	Connection cable for nebulizers	50
11.2	Anschlusskabel für Transformator	50
12	Appendix	51
12.1	h,x-diagram	51
12.2	Fresenius inspection certificate	52
12.3	CE Declaration of Conformity	53

1 Introduction

1.1 First things first!

Thank you for choosing the DRAABE humidification system.

The humidification system has been built using state-of-the-art technology and in accordance with the latest technical regulations. However, improper use of the systems may put users and/or third parties at risk and may also cause damage to material assets.

To ensure safe, proper and cost-efficient operation, please observe and comply with all information and safety instructions in this installation and operating instructions.

If you have any questions that are not answered or not answered adequately in this documentation, please contact your local Condair representative. We will be happy to assist.

1.2 Notes on the installation and operating instructions

Delimitations

The object of these installation and operating instructions are the DRAABE air humidifiers. The system components (e.g. PerPur, SynPur, HighPur, HumDigital II, etc.) are only described insofar as is necessary for proper operation.

As the system has various options for expansion, this documentation focuses on the basic system. Different system components are available depending on application and performance requirements. Higher humidification output has an impact on various system parts. Some accessories are not essentially required. Others are part of the standard configuration. Please see the customer-specific system diagram or contact your Condair representative for further information on accessory components and/or individual customer solutions.

The explanations in these installation and operating instructions are limited to:

- installation,
- commissioning,
- and parts of the operation and maintenance of the air humidifier.

The installation and operating instructions are supplemented by various separate documentation (brochures, order forms, diagrams, etc.). Where necessary, you will find corresponding cross-references to these publications in the installation and operating instructions.

Agreements



NOTE!

This symbol indicates important information. These are also made clear by the signal word "Note".



CAUTION!

The signal word "CAUTION" together with the hazard symbol in a circle indicates information provided in this documentation which, if ignored, could lead to **damage and/or the failure of the device or other equipment**.



WARNING!

The signal word "WARNING", together with the general hazard symbol, indicates safety and hazard information given in this documentation which, if ignored, **could lead to injury to people**. Other specific hazard symbols may also be used in place of the general symbol.



DANGER!

The signal word "DANGER", together with the general hazard symbol, indicates safety and hazard information given in this documentation which, if ignored, could lead to **severe injuries to persons or death**. Other specific hazard symbols may also be used in place of the general symbol.

Storage

Please keep these installation and operating instructions in a safe place where they can be accessed at all times. If the documentation is lost, please contact your Condair representative.

Language versions

These installation and operating instructions are available in various languages. For more information, please contact your Condair representative.

Definitions

- **Raw water:**
Raw water/mains water refers to drinking or tap water.
- **Soft water:**
Soft water refers to water produced by a softener. The water softening process involves replacing the water hardeners calcium and magnesium with sodium.
- **Pure water (RO water):**
Pure water or reverse osmosis water (RO water) refers to water demineralized by the pure water system (DRAABE DuoPur). Pure water is indispensable as a precursor for the smooth operation of the synthesis stage (DRAABE SynPur).
- **Ultrapure water (purified water):**
Ultrapure, or purified, water contains no minerals. This is produced in a synthesis cartridge, which removes the remaining minerals from pure water (RO water).
- **Product:**
The product is manufactured in PerPur/SynPur. The ultra-pure water (purified water) is conditioned with an additive and is suitable for humidifying rooms, etc.
- **Additive:**
The additive is CO₂ (carbon dioxide) gas, which is added to purified water to enable humidification with purified water.

2 For your safety

2.1 Intended use

The humidification system is intended **only for controlled air humidification within the specified operating parameters in areas that are not potentially explosive. Any other use is deemed improper and can render the system hazardous.**

Intended use also includes compliance with all information in these instructions (particularly the safety instructions) and strict compliance with the operating conditions.

2.2 General safety notices

- The humidification system may only be installed and operated by persons familiar with the product and adequately qualified for the respective work. It is the customer's responsibility to ensure that the installation and operating instructions are supplemented by in-house instructions regarding supervision and reporting requirements, work organization, personnel qualification, etc.
- **Before commencing any work on components** of the humidification system, it must be **properly shut down** and protected against unintentional start-up (disconnect from the power supply, shut off water supply and depressurize systems).
- Observe **all local safety regulations**:
 - for handling mains-powered **electrical and electronic devices**.
 - for **use with water and low pressure air systems**.
- Poorly maintained humidification systems can endanger health. The maintenance intervals must therefore be strictly observed and the maintenance work carried out correctly.
- If it can be assumed that **safe operation is no longer possible**, then the humidification system **must be shut down immediately, safeguarded against accidental switching on** and Condair must be informed. This may occur under the following circumstances:
 - if system components are damaged.
 - if the system is no longer working correctly.
 - if connections or pipes are leaking.
- The nebulizers are IP21 protected. Ensure that the equipment at the installation site is protected against dripping water and splash water.
- To avoid water damage, do not store water-sensitive materials directly under the system components.
- **CAUTION Risk of corrosion!** To avoid damage, there should be no corrosion-sensitive components in the area of the aerosol mist. The specified clearances below and in front of the nebulizers must be strictly observed (see [Section 5.2.1](#), [Section 5.3.2](#) and [Section 5.4.2](#)).

- The nebulizers may only be operated with treated water (pure or ultrapure water).



DANGER!
Health risk!

Due to health risks, the silicate content in the supply water to the nebulizers – in any form – must not exceed 12 mg/l.

If the silicate content of the supply water is higher a silicate filter must mandatory be installed in the water supply line before the water treatment system by the customer.

For further product-specific restrictions on water treatment system with regard to the silicate content, please note the relevant water supply requirements for the respective water treatment system.

- Depending on the mineral content in pure water (generated by water softener and reverse osmosis), a higher or lower level of mineral precipitation may form in the area of the aerosol mist. Sensitive materials and devices must be protected accordingly or removed from the area.
- Apart from the work described in this manual, no further interventions may be carried out on the humidification system.
- Only use original Condair accessories and spare parts.
- No modifications may be made to the humidification system without the written consent of Condair.
- Any changes to the system are subject to approval from Condair's customer service or persons authorized by Condair prior to it being started up for the first time.
- The highest level of hygiene is ensured right from the packaging and shipment of the goods. The goods may only be stored in dry, clean rooms where there is no risk of frost. Only remove the goods from the packaging immediately before installation in order to protect them against soiling of any kind. Please remove system parts that are only required for commissioning immediately before they are removed from the packaging.

Recommendation for fire extinguishing system:

Fire extinguishers suitable for use of electrical facilities up to 1000 V are permitted. Extinguishing agents may include BC extinguishing powder or carbon dioxide (CO₂).

3 Product overview

3.1 Functional description

Only water for nebulization and the power supply must be supplied to the nebulizers as single-substance nebulizers.

For all types, the water supply is provided by the DRAABE DuoPur/TrePur/HighPur high-pressure pure water system and the power supply is provided via the DRAABE HumPower II (120-230 VAC, 50-60 Hz and 24VDC).

The room air humidity is recorded in a humidification zone and as soon as it falls below the set value, the humidification zone requests water from the high-pressure system. If the humidification zone is notified by DRAABE HumCenter II that an operating pressure of 85 bar has been reached, it triggers the nebulizer with its power supply. As soon as this reaches the nebulizer, a ventilator and a magnetic valve (MV) are switched on; humidification is active.

The humidification output of the atomizers can be set individually in some cases by selecting the nozzles. The nozzles have a capacity in the increments 1.2 l/h, 1.6 l/h, 2.4 l/h and 4.0 l/h. It can also be easily adapted after installation if required. Contact your sales partner.

3.2 Equipment overview

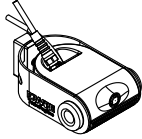
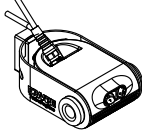
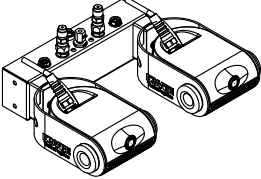
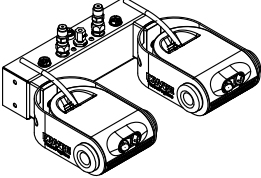
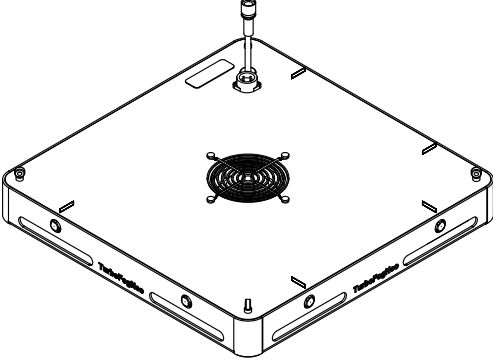
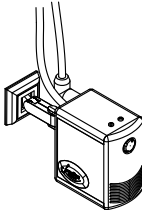
Nebulizer	Name of device	Number of nozzles	Humidification output ¹⁾ [l/h]
	TurboFogNeo 1	1	1,6 - 4,0
	TurboFogNeo 2	2	3,2 - 8,0
	TurboFogNeo 2x1	2	3,2 - 8,0
	TurboFogNeo 2x2	4	6,4 - 16,0
	TurboFogNeo 8	8	19,2 - 32,0
	NanoFogEvolution	1	1,2 - 1,6
	NanoFogSens	1	1,2 ²⁾

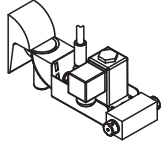
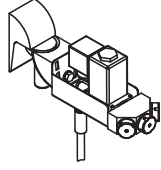
	DI Flex 2 M – MK	2	3,2 – 8,0
	DI Flex 2 L – MK		
	DI Flex M – MK	3	4,8 – 12,0
	DI Flex L – MK		

- ¹⁾ The humidification output depends on the selection of the corresponding high-pressure nozzle. The minimum power for equipping with S nozzles and the maximum possible power for equipping with XL nozzles are specified.
- ²⁾ The NanoFogSens can also be technically equipped with a larger nozzle. In practice, however, this is not always possible, as a smaller and quieter fan is installed here. If a different nozzle is desired, contact your sales partner.

3.3 Equipment structure

3.3.1 TurboFogNeo 1, 2, 2x1 and 2x2

Figure shows TurboFogNeo 1

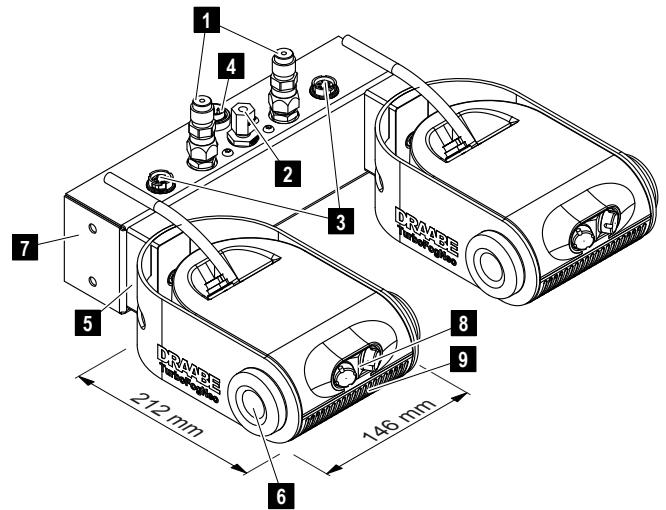
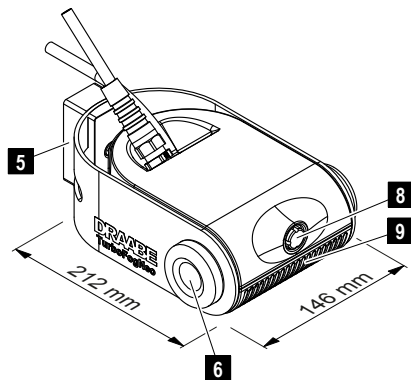

Figure shows TurboFogNeo 2x2

Fig. 1: Equipment structure TurboFogNeo 1, 2, 2x1 and 2x2

Key

- | | | | |
|---|--|---|---|
| 1 | 2x connection for quick coupling of the high-pressure ring line to the atomizer | 5 | Three-part wall bracket for mounting and horizontal alignment of the device. |
| 2 | 1x connection for high-pressure supply line from the high-pressure ring to supply the wall bracket | 6 | 2x screw connections for vertical alignment of the device |
| 3 | 2x connection for power supply to the nebulizers | 7 | Two-arm wall bracket with connections for the electrical and hydraulic supply |
| 4 | 1x connection for the power supply of the wall bracket | 8 | High-pressure nozzle |
| | | 9 | Fan outlet opening |

3.3.2 TurboFogNeo 8

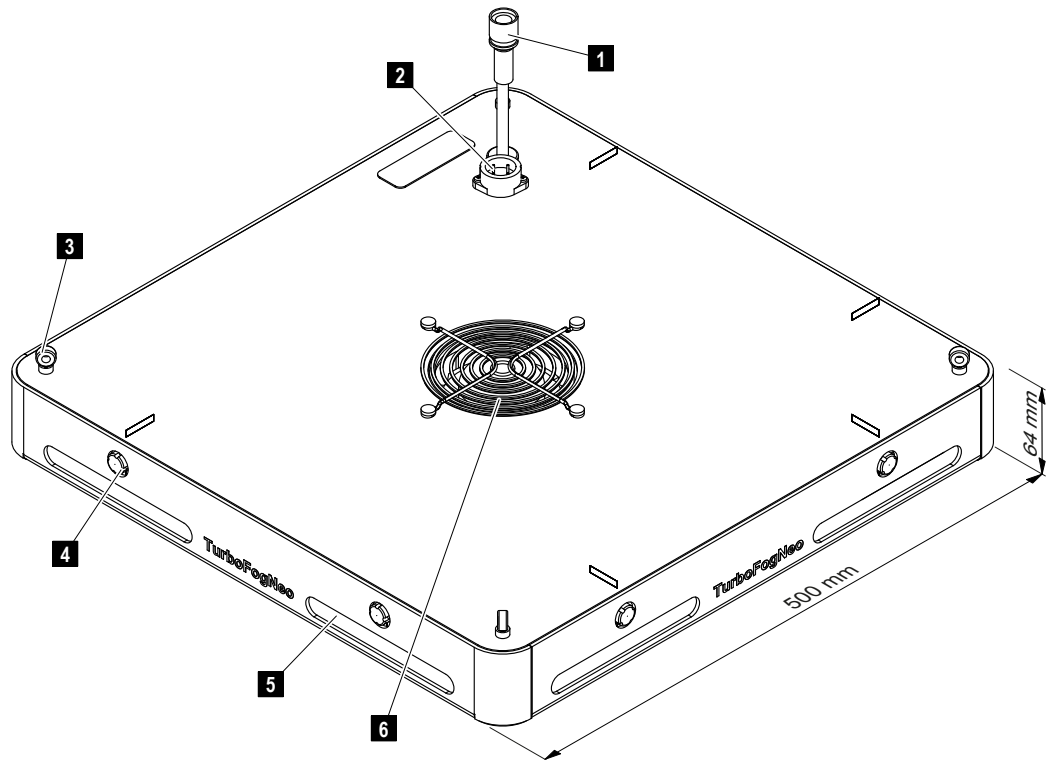

Fig. 2: Equipment structure TurboFogNeo 8

Key

- | | |
|--|---------------------------|
| 1 Quick coupling for the hydraulic connection | 4 8x high-pressure nozzle |
| 2 Socket with pin contacts for connecting the supply voltage | 5 8x fan outlet opening |
| 3 4x eyelet for fastening the chains (ceiling installation) | 6 Fan grid for air inlet |

3.3.3 NanoFogEvolution / NanoFogSens

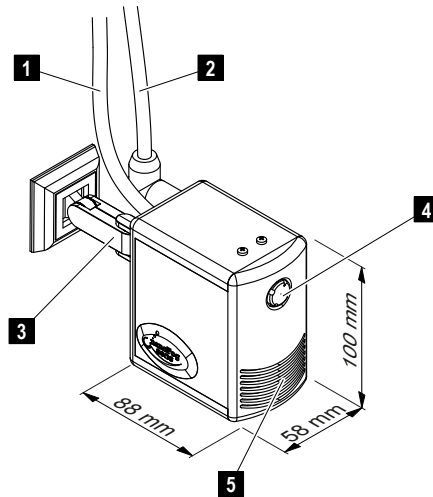

Fig. 3: Equipment structure NanoFogEvolution / NanoFogSens

Key

- | | |
|---|---|
| 1 High-pressure hose with quick coupling for hydraulic connection | 3 Wall mounting bracket for wall mounting |
| 2 Supply line for the electrical connection with angular coupling | 4 High-pressure nozzle |
| | 5 Fan outlet opening |

3.3.4 DI Flex 2 M – MK / DI Flex 2 L – MK

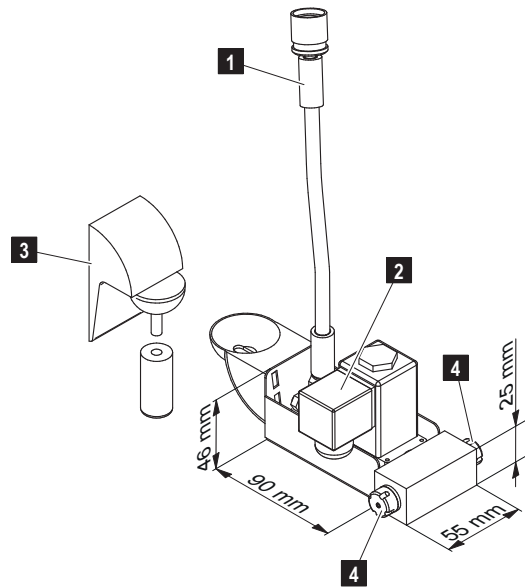

Fig. 4: Equipment structure DI Flex 2 M / DI Flex 2 L

Legend

- | | | | |
|---|--|---|---|
| 1 | High-pressure hose with quick coupling for hydraulic connection (Quick coupling only for devices with the suffix "- MK") | 3 | Wall mounting bracket for wall mounting |
| 2 | Electrical connection | 4 | High-pressure nozzles |

3.3.5 DI Flex M – MK / DI Flex L – MK

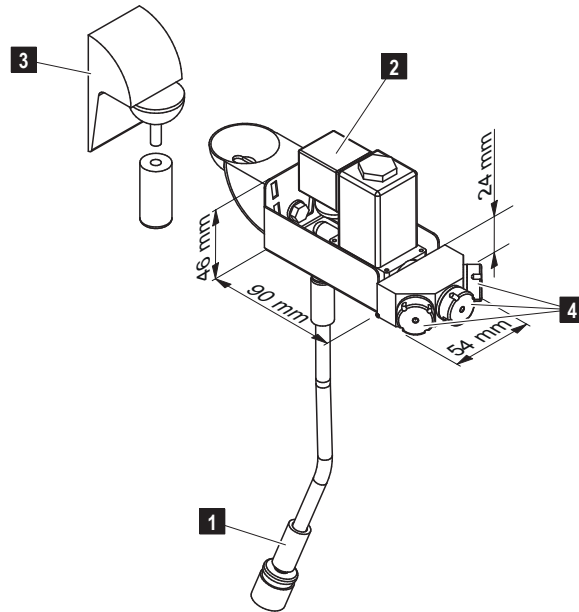

Fig. 5: Equipment structure DI Flex M / DI Flex L

Legend

- | | |
|--|---|
| 1 High-pressure hose with quick coupling for hydraulic connection (Quick coupling only for devices with the suffix "- MK") | 3 Wall mounting bracket for wall mounting |
| 2 Electrical connection | 4 High-pressure nozzles |

3.4 High-pressure nozzles

3.4.1 Design

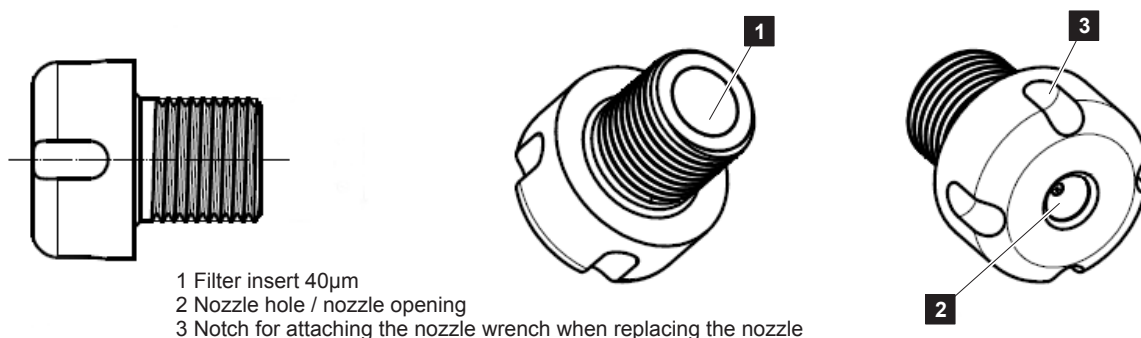

Fig. 6: High-pressure nozzle design

3.4.2 Properties

The nozzles mainly differ in terms of the liter output during operation. The design and properties are identical. The letter (S, M, or L) is embossed on the nozzle edge to distinguish between the nozzles.

The humidification output relates to the working pressure at 85 bar. The pressure in the high-pressure ring is highly dynamic due to installation and the frequency-controlled high-pressure system. On average, a working pressure of 85 bar is achieved at the nozzles.

Variant [Nozzle type]	Operating pressure [bar]	Humidification output [l/h]	Droplet size [µm]	Cleanroom class (ISO 14644-1) ¹⁾
S nozzle	Min. 50 Typical: 85 Max. 110	Up to 1.0	< 15	7, 8, 9
M nozzle	Min. 50 Typical: 85 Max. 110	Up to 1.5	< 15	7, 8, 9
L nozzle	Min. 50 Typical: 85 Max. 110	Up to 2.5	< 15	7, 8, 9
M nozzle (DI Flex M)	Min. 50 Typical: 85 Max. 110	1,6	< 15	7,8,9
L nozzle (DI Flex L)	Min. 50 Typical: 85 Max. 110	2,1	< 15	7,8,9
XL nozzle	Min. 50 Typical: 85 Max. 110	4,0	~ 15	none

¹⁾ The droplet size and number of droplets in the aerosol mist decreases with increasing distance from the nozzle and corresponds to the conditions for cleanroom class 7 in accordance with DIN EN ISO 14644-1.

**CAUTION!****Use of ultrapure water (DI water) in clean rooms**

The nozzles can be operated with pure water (RO water) or ultrapure water (DI water). Residual minerals in pure water can lead to dust formation in the room. Operation with ultrapure water is therefore planned for use in cleanrooms!

**CAUTION!****Use of ultrapure (DI) water and S-nozzles**

Due to their micro-fine bore, S nozzles should not be operated with pure water. The remaining residual minerals may clog the nozzle.

4 Installation overview

4.1 TurboFogNeo / NanoFog

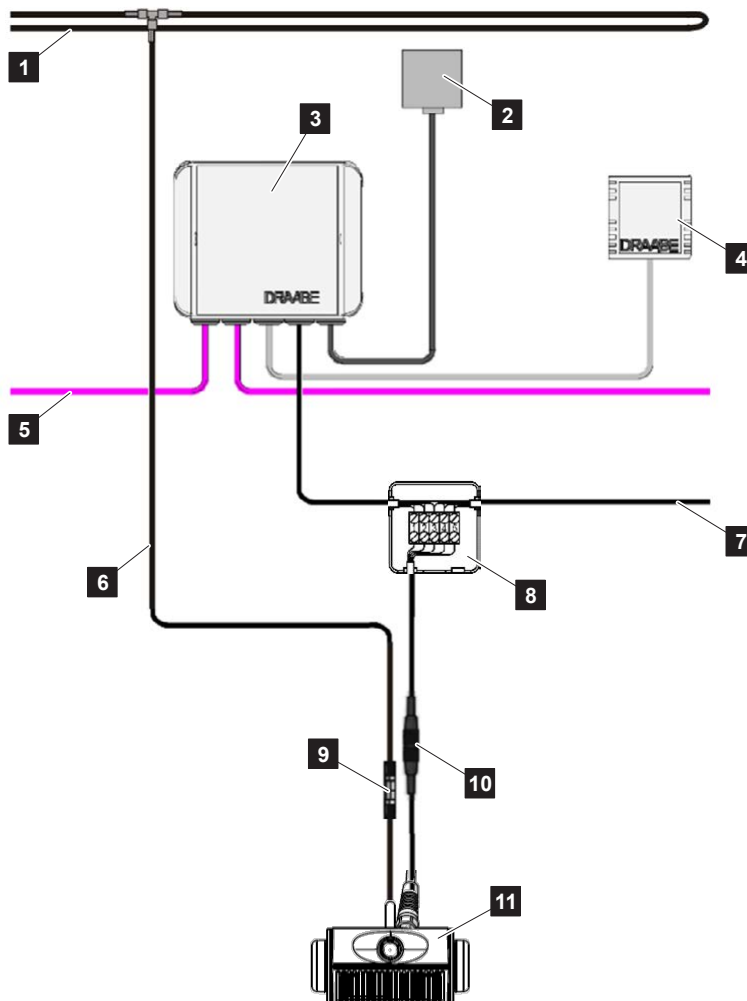

Fig. 7: Installation overview TurboFogNeo / NanoFog

Legend

- | | |
|--|---|
| 1 High-pressure ring line (DN8/DN4), supply and return from high pressure pulsation system | 6 Stub from high-pressure ring (DN4) |
| 2 Fixed connection for the supply voltage (120-230VAC) of the nebulizer / HumPower | 7 Control line to (further) nebulizers, max. 10 pcs. per HumPower |
| 3 HumPower II, HumDigital II control unit | 8 Junction box (optional when connecting a nebulizer) |
| 4 Maximum humidistat, safety switch-off if the set air humidity is exceeded | 9 Quick-release coupling, self-closing for hydraulic connection |
| 5 CAN bus line from HumCenter II or to the next HumDigital II control unit | 10 Plug/socket for nebulizer connection |
| | 11 Nebulizer (here e.g. TurboFogNeo 1) |

4.2 DI Flex / DI Flex 2

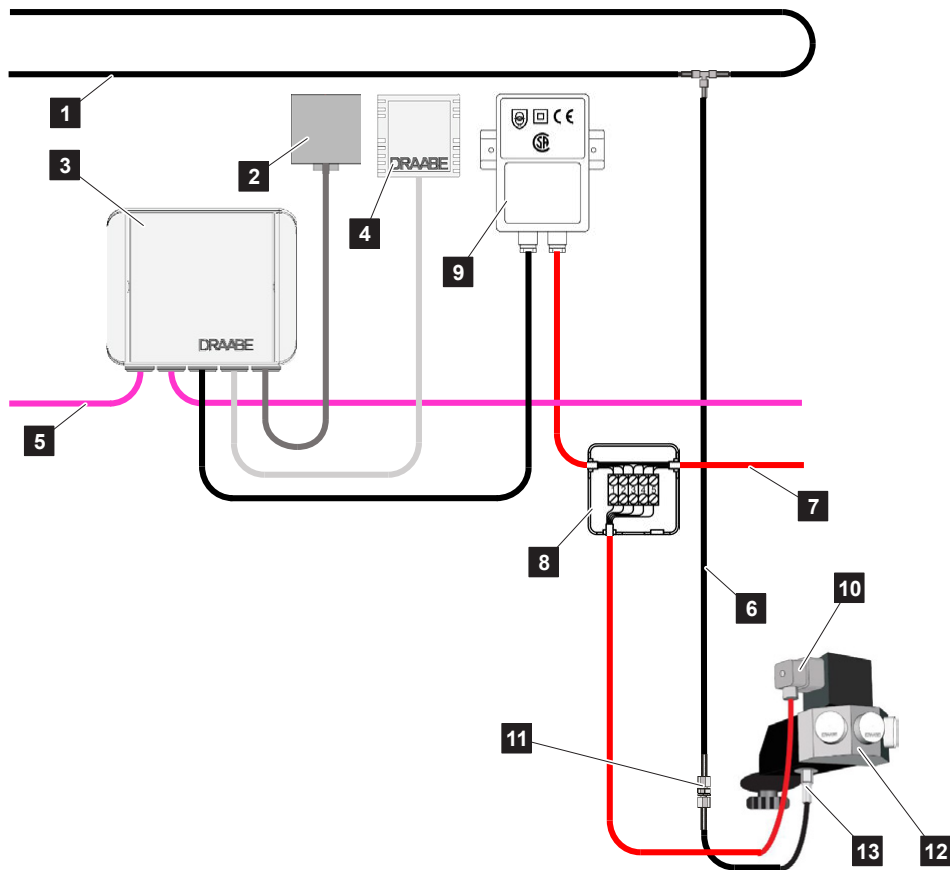

Fig. 8: Installation overview DI Flex / DI Flex 2

Legend

- | | |
|--|---|
| 1 High-pressure ring line (DN8/DN4), supply and return from high pressure pulsation system | 8 Junction box (for connecting a maximum of 2 nebulizers, optional when connecting one nebulizer) |
| 2 Fixed connection for the supply voltage (120-230VAC) of the nebulizer / HumPower | 9 Transformer, 230V/48V AC, 75VA, max. 1 pc / HumPower |
| 3 HumPower II, HumDigital II control unit | 10 Socket connector for nebulizer connection |
| 4 Maximum humidistat, safety switch-off if the set air humidity is exceeded | 11 Self-closing quick-release coupling (only for DI-Flex devices with the suffix "-MK") |
| 5 CAN bus line from HumCenter II or to the next HumDigital II control unit | 12 Nebulizer (here e.g. DI Flex) |
| 6 Stub from high-pressure ring (DN4), max. 4 m | 13 Hydraulic connection on the nebulizer, not self-closing! |
| 7 Control line to (further) nebulizers, max. 7 pcs. per transformer | |

5 Mounting the nebulizers

5.1 General information on positioning

The following **information on positioning must be referred to and complied with:**

- There must be no deflector surfaces facing in the direction of the mist. Otherwise, condensation or precipitation – and therefore dripping water – may occur.
- The air space in front should be free at a 90° angle and a distance of 4 m.
- Within the specified free area (air space at the front, distance from ceiling and floor), there must not be any ventilation ducts, system components or other parts / goods sensitive to humidity.
- The stubs with the high-pressure hose DN4 extending from the short T-connector (ring line) must not be longer than 4 m.
- The nebulizers must not be placed directly over workstations or machines. In workplaces, an impairment of the working environment due to evaporative cooling of the aerosols is to be expected. Machines and materials can be damaged in the event of malfunctions due to dripping water
- Safety devices such as fire detectors or alarm systems may react to aerosol mist under certain circumstances. This must be ruled out during installation.



NOTE!

The evaporation distance (free air gap in front of the nebulizer) described in the following sections varies depending on the place of use, the prevailing temperature, the relative humidity and the air flow. The specifications are selected in such a way that the evaporation distance is not exceeded under expected conditions.

5.2 Mounting the TurboFogNeo 1, 2, 2x1, 2x2

5.2.1 Positioning the TurboFogNeo 1, 2, 2x1, 2x2

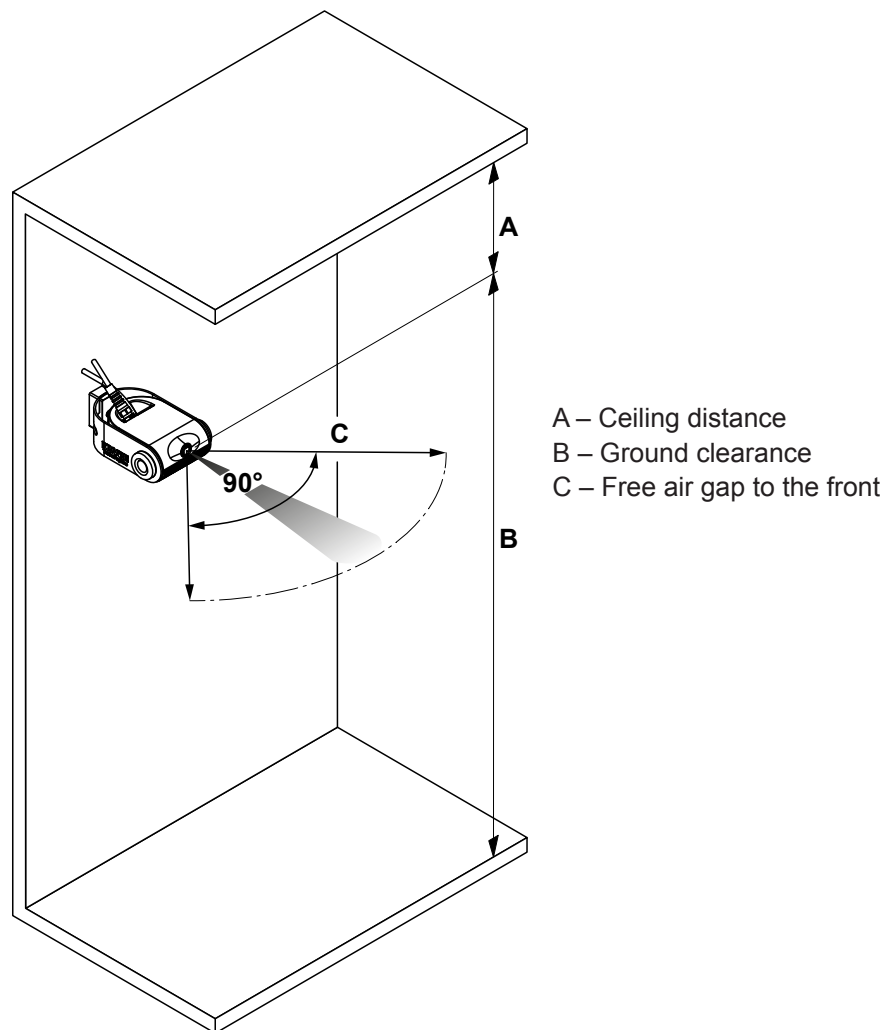

Fig. 9: Positioning the TurboFogNeo 1,2,2x1,2x2

Equipment type	Ceiling distance (A)	Ground clearance (B)	Free air gap (C)
TurboFogNeo 1	0.5 m	2.4 m	4.0 m
TurboFogNeo 2	1.0 m	3.0 m	4.0 m
TurboFogNeo 2x1	0.5 m	3.0 m	4.0 m
TurboFogNeo 2x2	1.0 m	4.0 m	4.0 m

5.2.2 Mounting the TurboFogNeo 1 and 2

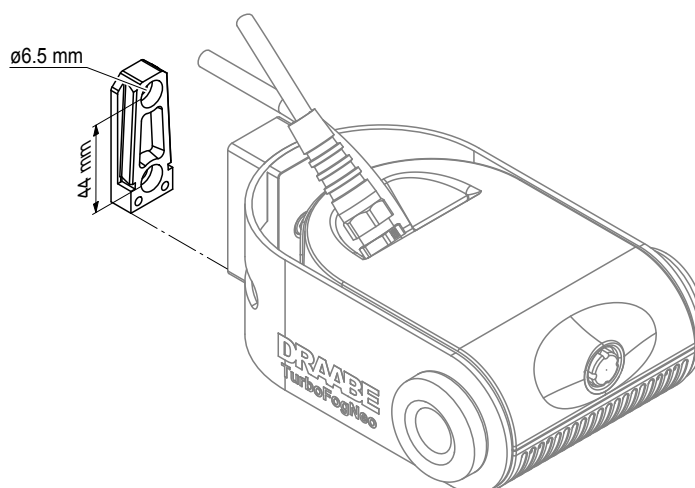

Fig. 10: Mounting TurboFogNeo 1 and 2 nebulizers

5.2.3 Mounting the TurboFogNeo 2x1 and 2x2

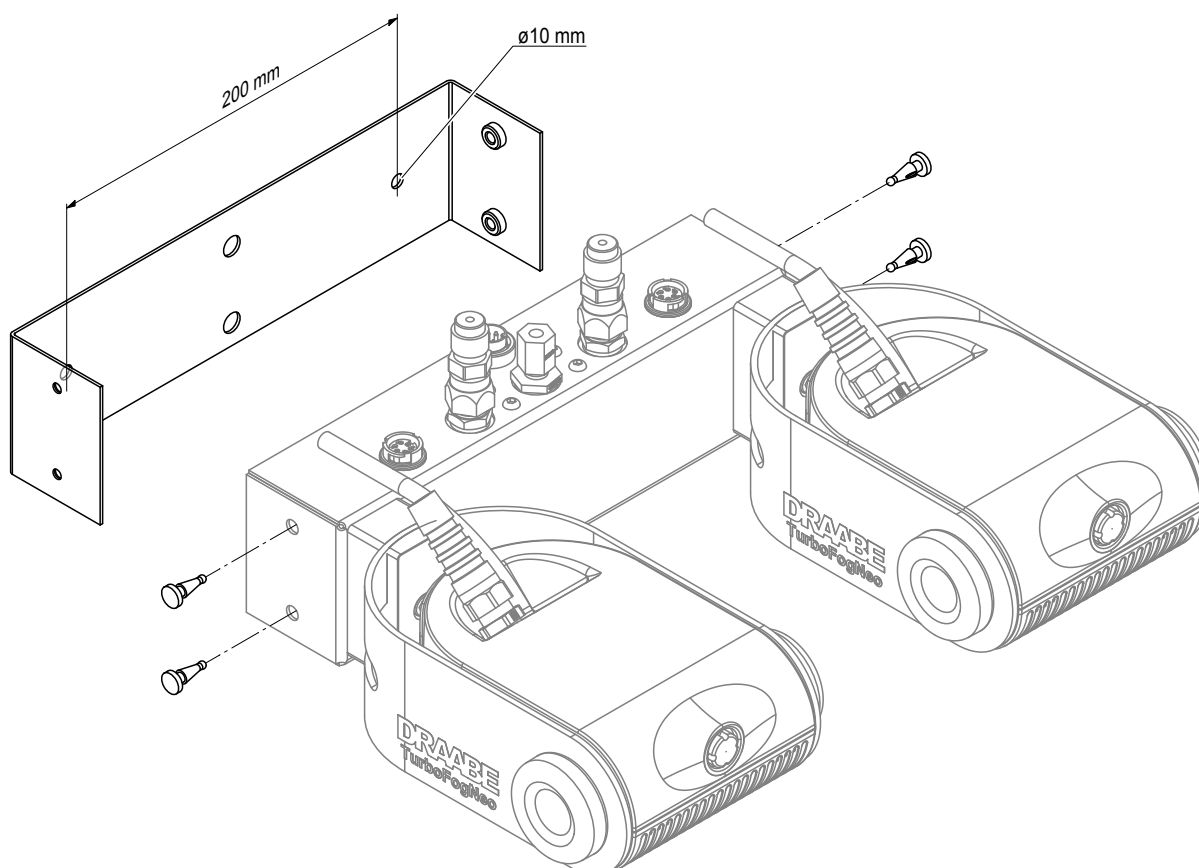

Fig. 11: Installing a wall bracket with two supporting brackets for TurboFogNeo 2x1 and 2x2 nebulizers

5.3 Mounting the TurboFogNeo 8

5.3.1 Additional information on positioning the TurboFogNeo 8

- The maximum installation height should not be exceeded so as to not make access unnecessarily difficult.
- The air space in front should be free at a 360° angle and a distance of 4 m. (For further details, see the graphic below)
- The stubs with the DN4 high-pressure hose, starting from the short T-connector, must not exceed 6 m in length.

5.3.2 Positioning the TurboFogNeo 8

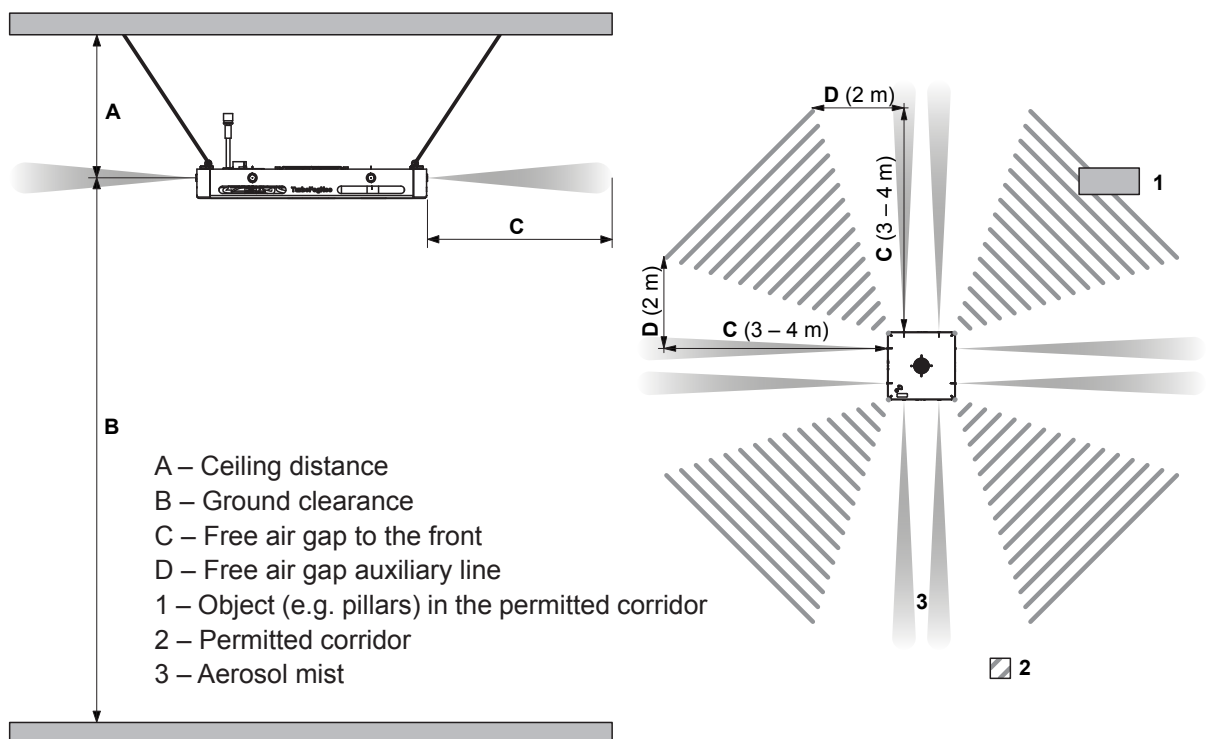

Fig. 12: Positioning the TurboFogNeo 8

Minimum clearances	TurboFogNeo 8
Ceiling clearance [A]	1.0 m
Floor clearance [B]	4.0 – 6.0 m
Free air gap [C]	3.0 – 4.0 m
Free air gap [D]	2.0 m

5.3.3 Mounting the TurboFogNeo 8

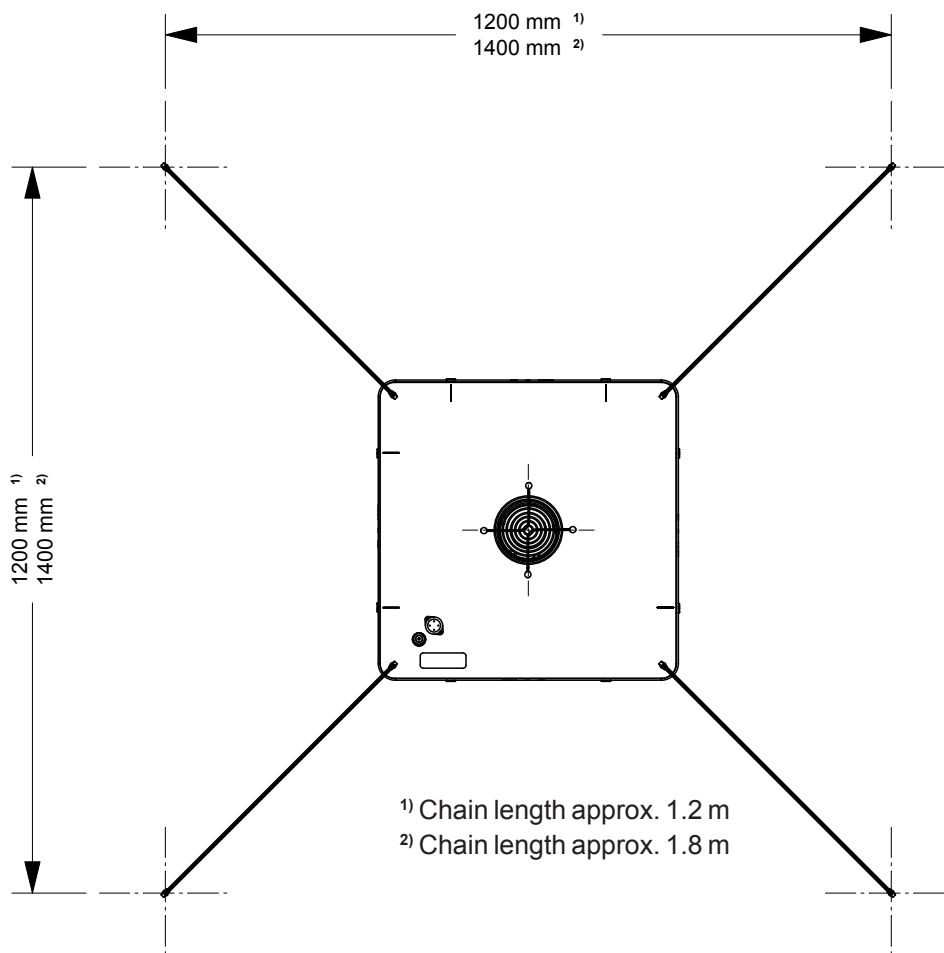

Fig. 13: Hole dimensions for chain suspension – TurboFogNeo 8

5.4 Mounting the NanoFogEvolution / NanoFogSens

5.4.1 Additional information on positioning the NanoFogEvolution / NanoFogSens

Lay the stub and cable to the wall bracket in a cable duct (45 x 30 mm). To make it easier to replace the nebulizer, make one cut in the cover of the cable duct at a distance of 30 cm from the wall bracket.

5.4.2 Positioning the NanoFogEvolution / NanoFogSens

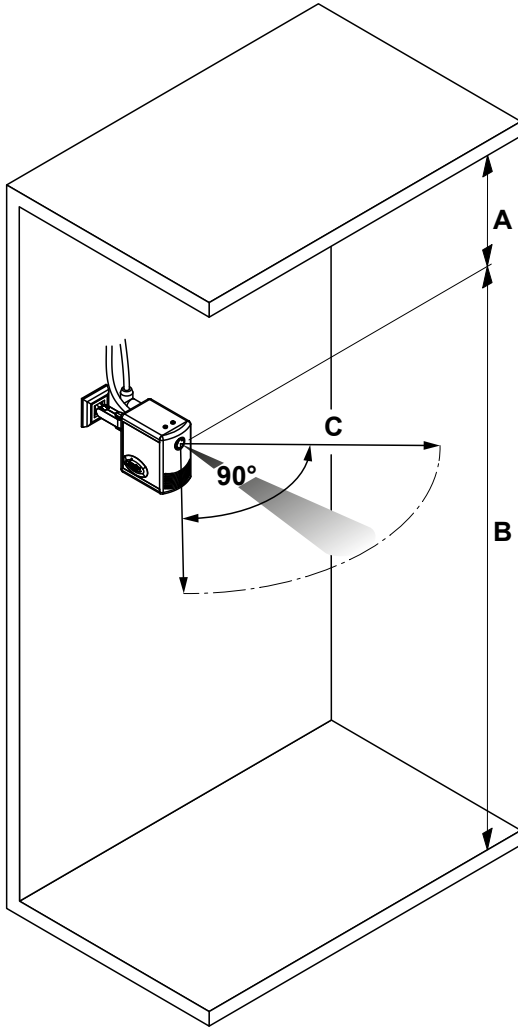

Fig. 14: Positioning the NanoFogEvolution / NanoFogSens

Equipment type	Ceiling distance (A)	Ground clearance (B)	Free air gap (C)
NanoFogEvolution	0.2 m	2.0 m	4.0 m
NanoFogSens	0.2 m	2.0 m	4.0 m

5.4.3 Mounting the NanoFogEvolution / NanoFogSens

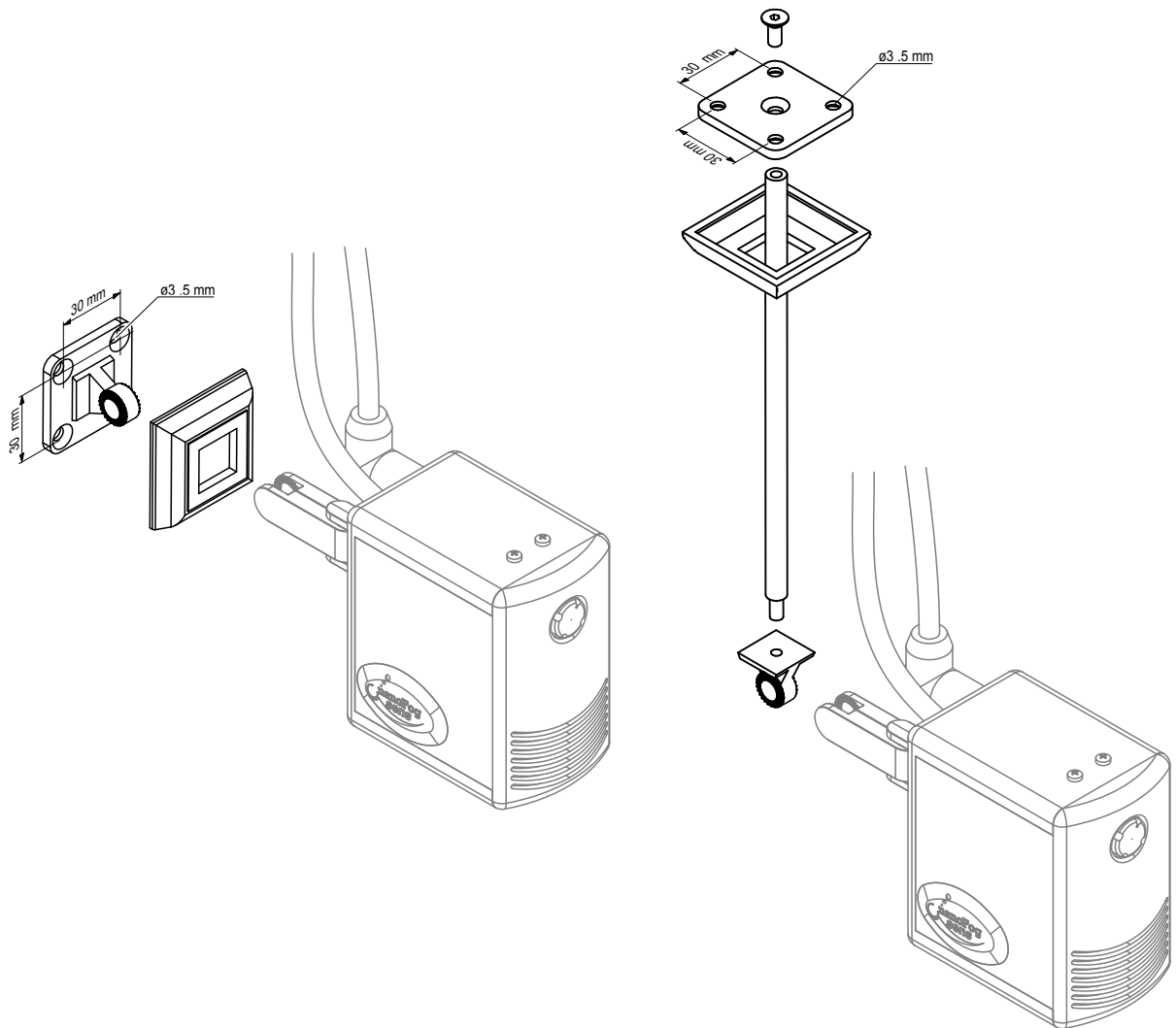

Fig. 15: Wall and ceiling mounting NanoFogEvolution / NanoFogSens nebulizers

5.5 Mounting the DI Flex 2

5.5.1 Additional information on positioning the DI Flex 2

The high-pressure line with fittings (stub line, DN4) and the cable for the power supply (provided with the special plug) must be routed to the nebulizer. A clean installation is achieved if both supplies are routed in a protective tube (contents of the DRAABE quick installation kit).

5.5.2 Positioning the DI Flex 2

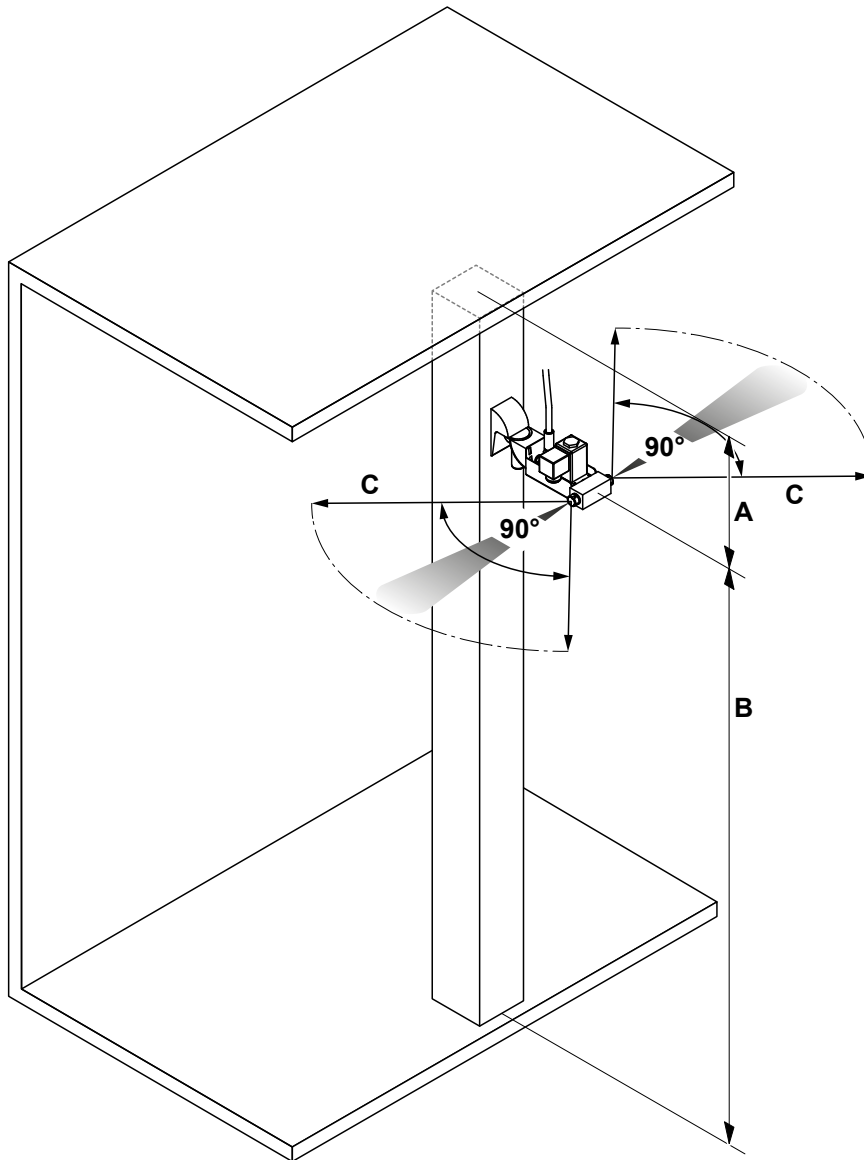

Fig. 16: Positioning the DI Flex 2

Equipment type	Ceiling distance (A)	Ground clearance (B)	Free air gap (C)
DI Flex 2 M	0.5 m	4.0 m	4.0 m
DI Flex 2 L	0.5 m	5.0 m	4.0 m

5.5.3 Mounting the DI Flex 2

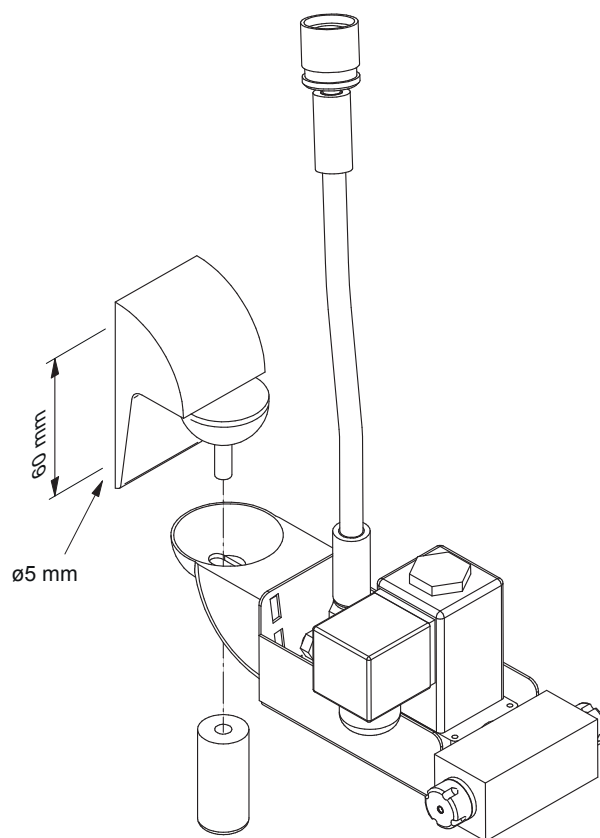

Fig. 17: Wall mounting DI Flex 2 nebulizers

5.6 Mounting the DI Flex

5.6.1 Additional information on positioning the DI Flex

The high-pressure line with fittings (stub line, DN4) and the cable for the power supply (provided with the special plug) must be routed to the nebulizer. A clean installation is achieved if both supplies are routed in a protective tube (contents of the DRAABE quick installation kit).

5.6.2 Positioning the DI Flex

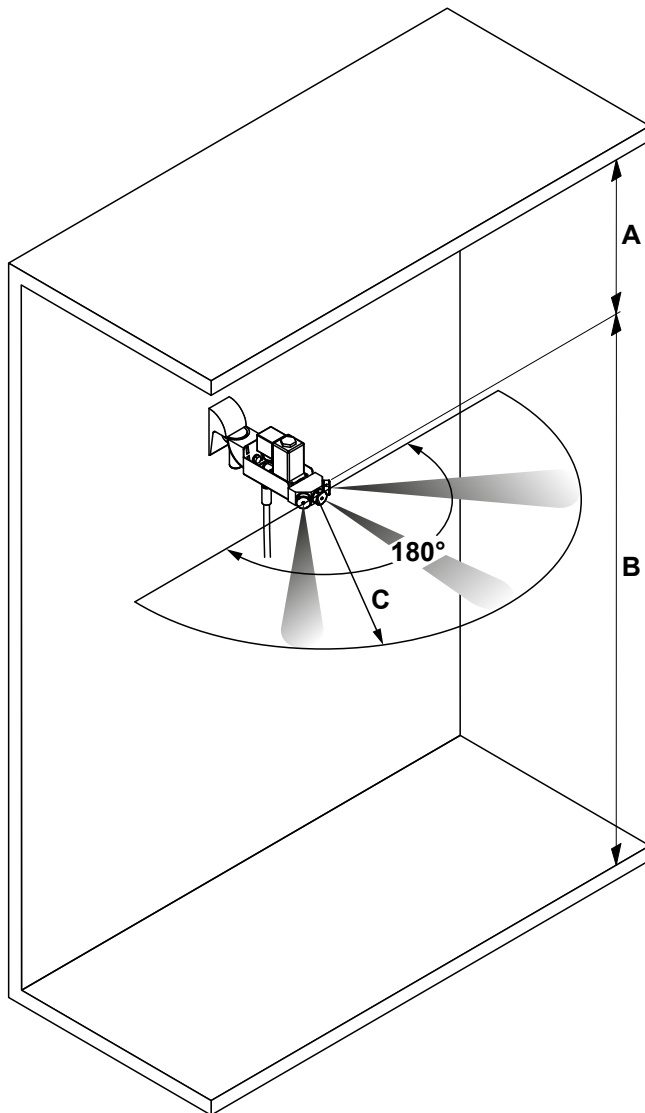

Fig. 18: Positioning the DI Flex

Equipment type	Ceiling distance (A)	Ground clearance (B)	Free air gap (C)
DIFlex M	0.5 m	4.0 m	4.0 m
DI Flex L	0.5 m	5.0 m	4.0 m

5.6.3 Mounting the DI Flex

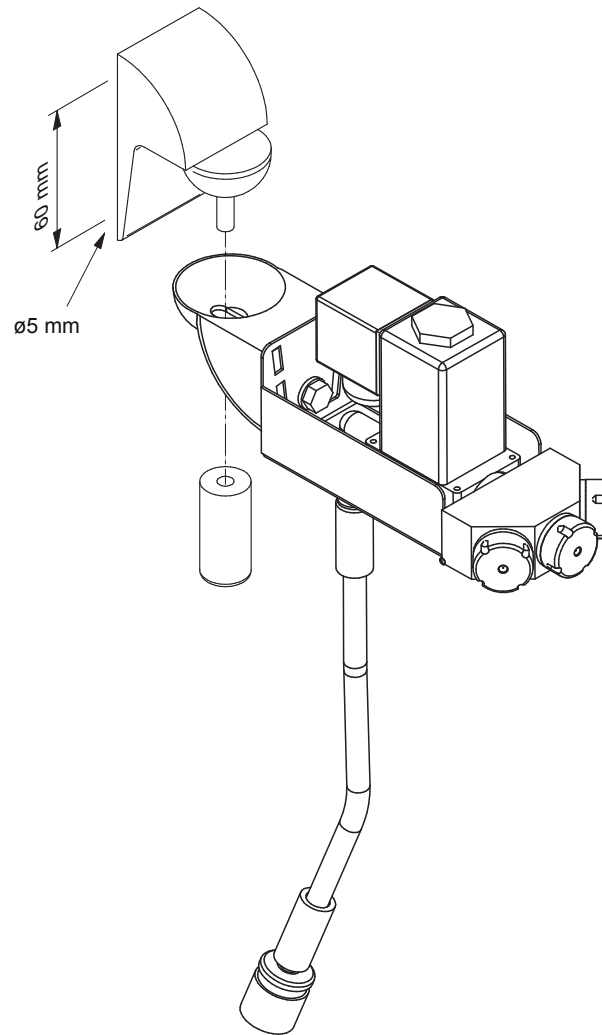

Fig. 19: Wall mounting DI Flex nebulizers

6 Hydraulic connection of the nebulizers

6.1 Installing the high-pressure hose

The water is pressurized up to 85 bar and is fed from the removable console of the high-pressure pure water system (HighPur, TrePur, DuoPur) into the high-pressure loop (DN8/DN4, max. 800 m). The individual nebulizers are supplied from the high-pressure ring (stub, DN4, max. 4 m). Each nebulizer has a T-connector for connecting to the stub.

6.2 General information

- Use only components that comply with the material specifications.
- The hoses of the ring line must be laid in a protective pipe.
- If the hoses are to be laid through an opening in the wall (with or without press-on fittings), the respective end must be sealed during installation to prevent dirt from entering the hose.
- Do not bend the hoses tighter than the following minimum bend radii:
 - DN8 hose: 115 mm
 - DN4 hose: 40 mm
- The recommended distance for the high-pressure hose brackets is 1.0 m
- When pressing the fittings, the specifications in accordance with the table in [Section 6.3](#) must be observed. You must check the pressing dimensions and correct compression of each fitting. Fittings that have been compressed incorrectly must be replaced.



CAUTION!

Damage to the hose due to incorrect installation

When laying the hoses you must ensure that they do not rub on corners, wall ducts or openings, etc. so that the high-pressure hose does not become damaged. Please remember that the hose may expand or contract due to differences in pressure and temperature.

6.3 Compressing the high-pressure hoses

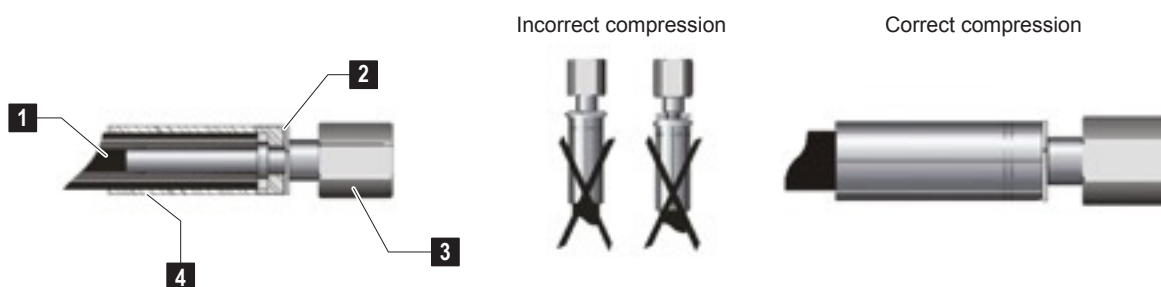

Fig. 20: Compressing the high-pressure hoses

Key

- 1 High-pressure hose
- 2 Plastic disc
- 3 Union nut
- 4 Ferrule

Pressing dimensions

Hose	Internal diameter in mm	Fitting	Ferrule diameter, non-pressed in mm	Ferrule diameter, pressed in mm	Tolerance in mm	Pressing dimensions setting at the measuring screw of the UNIFLEX HD press
DRAABE HD2000 (week/year) DN04 Batchno. 12.5 MPa (125 bar)	4.0	DKOL-06L-DN4	13	11	±0.1	2
DRAABE HD2000 (week/year) DN08 Batchno. 12.5 MPa (125 bar)	7.9	DKOL-10L-DN8	19	16	±0.1	3

7 Electrical connection of the nebulizers

7.1 General connection instructions

The documentation does not cover installation of the mains power. However, it does contain requirements for the latter. The installation of the electrical components of the DRAABE nebulizer high-pressure pure water system is described, as is the location for installing the mains power.

Notes on electrical installation:

- The connected nebulizers must be suitable for the voltage ranges of the fixed connection (120V OR 230V) (observe the type plate specifications).
- In the case of screw connections, the flexible cable ends must be provided with suitable ferrules.
- When connecting the lines with cable splice connectors (e.g. Wago 221-615), the ferrules can be omitted.
- The specified values for safeguarding must be observed and complied with.
- The maximum permissible output of the power supply devices (HumPower II and transformer) must not be exceeded when several nebulizers are connected.
- The system must be installed exclusively in accordance with the diagrams discussed in this document.
- Switch off the power supply during installation and secure the system against being switched on accidentally.
- The devices comply with protection class IP20 at a minimum. The ambient conditions must be suitable for this protection class.



DANGER!
Risk of electrocution

The DRAABE nebulizers work with mains voltage (230V AC, 50Hz or 120V AC, 60Hz).

For this reason: Before starting work on the electrical connections, make sure that the control unit (HumPower II) is disconnected from the power supply (switch off the fuse and secure it against being switched on again and ensure that it is de-energized).



DANGER!
FI protection

Water-carrying lines are installed in the devices themselves. Therefore, it can never be ruled out that water could come into contact with electrical parts. For this reason, the power supply must be provided via a residual current circuit breaker (FI switch).

7.2 Determination of the maximum number of nebulizers per power supply device

The HumPower II has a maximum AC output (120-230V, 50-60Hz) of 80W.

Furthermore, it can provide a maximum of 20 W via the DC voltage contact. The transformer (230/48 V, 50-60 Hz) to supply the DI-Flex devices can provide a maximum of 75 W.

This must be taken into account when designing the nebulisers! The performance of the nebulizers can be found in [Section 10 "Technical data"](#).

Example #1:		
Planned	AC power requirement	DC power requirement
10 x TFNeo1	10 x 4 W (=40 W)	10 x 1,73 W (=17,3 W)
Ergebnis:		
The HumPower still has a reserve of 40 W AC (80 W - 40 W) and 2.7 W DC (20 W - 17.3 W). The 10 TFNeo 1 devices can be connected to one HumPower.		

Example #2:		
Planned	AC power requirement	DC power requirement
10 x TFNeo 2x2	10 x 8 W (=80 W)	10 x 3,46 W (=34,6 W)
Result:		
The HumPower II cannot provide the required power of 34.6 W DC. A maximum of 5 x TFNeo 2x2 can be connected to a HumPower II.		
Alternatively, an additional HumPower II would have to be installed in the zone.		

7.3 Connection TurboFogNeo 1, 2, 2x1, 2x2

The scope of delivery of the quick installation kit (SMB) comprises a pre-packed 3 m supply cable, incl. plug (socket side) [3], and a junction box [2]. Only the supplied supply cable [3] may be used to connect the nebulizer.

You must ensure that the protective earth (color: green/yellow) is connected. All cable ends must be fitted with suitable ferrules.

Connect the connectors as follows:

Line [1.3] JZ-600 5x0.5mm ² ¹⁾	Line [1.3] YSLY-JB 5x0.5mm ² ¹⁾	Pin assignment [4] plug/socket	Description / function
1	Brown (BN)	1	Phase L1 (120 or 230 VAC)
2	Black (BK)	2	0 VDC / GND
3	Blue (BU)	3	Neutral conductor N (120 or 230 VAC)
4	Grey (GY)	4	24 VDC
Green/yellow (5)	Green/yellow (GN-YE)	5	Protective earth

¹⁾ Depending on the selected cable during installation, different cable types may have been selected.

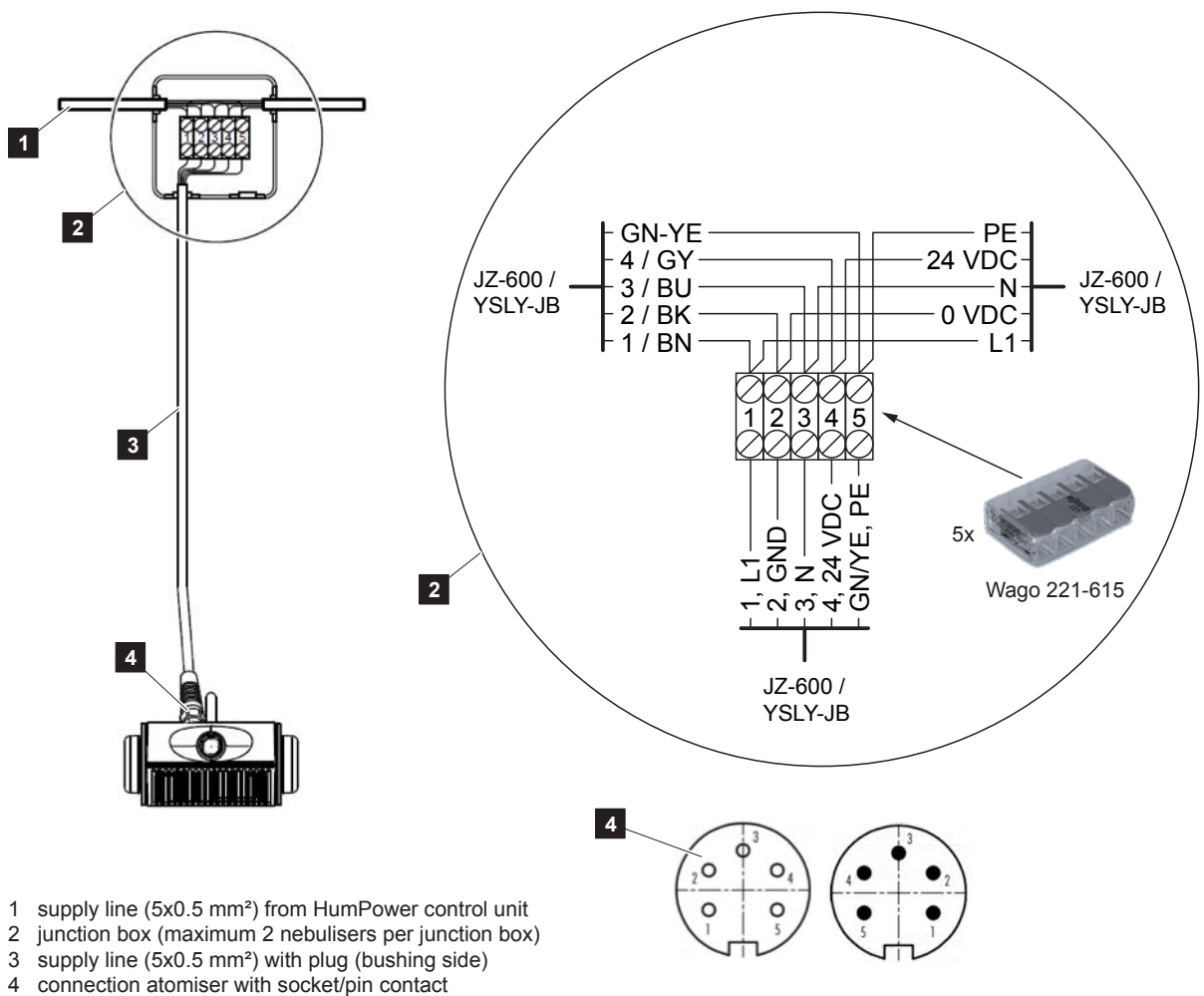

Fig. 21: Connection TurboFogNeo 1, 2, 2x1, 2x2

7.4 Connection TurboFogNeo 8

The scope of delivery of the quick installation kit (SMB) comprises a pre-packed 3 m supply cable, incl. plug (socket side) [3], and a junction box [2]. Only the supplied supply cable [3] may be used to connect the nebulizer.

You must ensure that the protective earth (color: green/yellow) is connected. All cable ends must be fitted with suitable ferrules.

The TurboFogNeo 8 nebulizer does not require a 24V DC voltage, unlike the other nebulizer types. The assignment of the corresponding terminals is left free during connection.

Connect the connectors as follows:

Line [1.3] JZ-600 5x0.5mm ² ¹⁾	Line [1.3] YSLY-JB 5x0.5mm ² ¹⁾	Pin assignment [4] plug/socket	Description / function
1	Brown (BN)	1	Phase L1 (120 or 230 VAC)
2	Black (BK)	-	0 VDC / GND
3	Blue (BU)	2	Neutral conductor N (120 or 230 VAC)
4	Grey (GY)	-	24 VDC
Green/yellow (5)	Green/yellow (GN-YE)	PE (4)	Protective earth

¹⁾ Depending on the selected cable during installation, different cable types may have been selected.

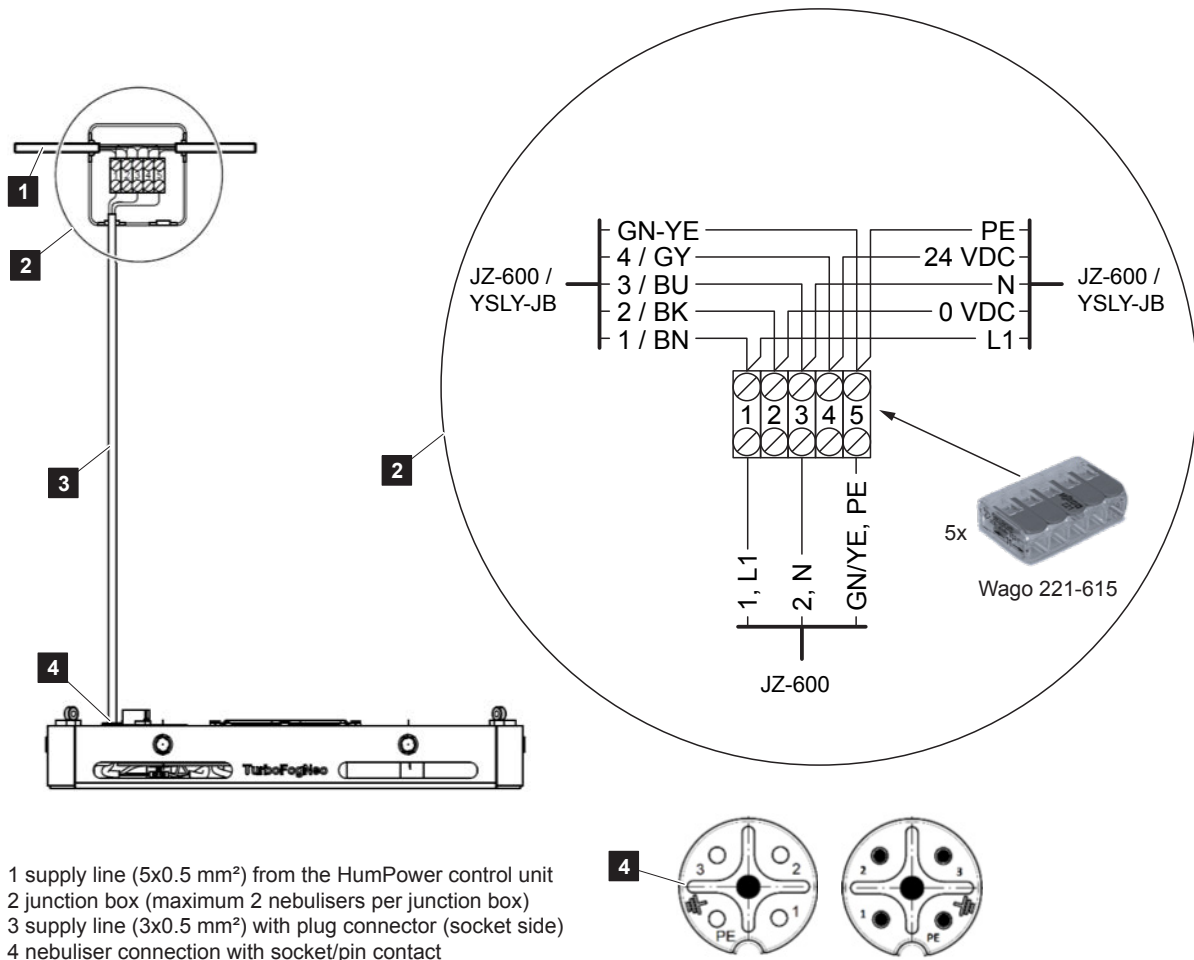

Fig. 22: Connection TurboFogNeo 8

7.5 Connection NanoFogEvolution / NanoFogSens

The scope of delivery of the quick installation kit (SMB) comprises a pre-packed 3 m supply cable, incl. plug (socket side) [3], and a junction box [2]. Only the supplied supply cable [3] may be used to connect the nebulizer.

You must ensure that the protective earth (color: green/yellow) is connected. All cable ends must be fitted with suitable ferrules.

Connect the connectors as follows:

Line [1.3] JZ-600 5x0.5mm ² ¹⁾	Line [1.3] YSLY-JB 5x0.5mm ² ¹⁾	Pin assignment [4] plug/socket	Description / function
1	Brown (BN)	1	Phase L1 (120 or 230 VAC)
2	Black (BK)	2	0 VDC / GND
3	Blue (BU)	3	Neutral conductor N (120 or 230 VAC)
4	Grey (GY)	4	24 VDC
Green/yellow (5)	Green/yellow (GN-YE)	5	Protective earth

¹⁾ Depending on the selected cable during installation, different cable types may have been selected.

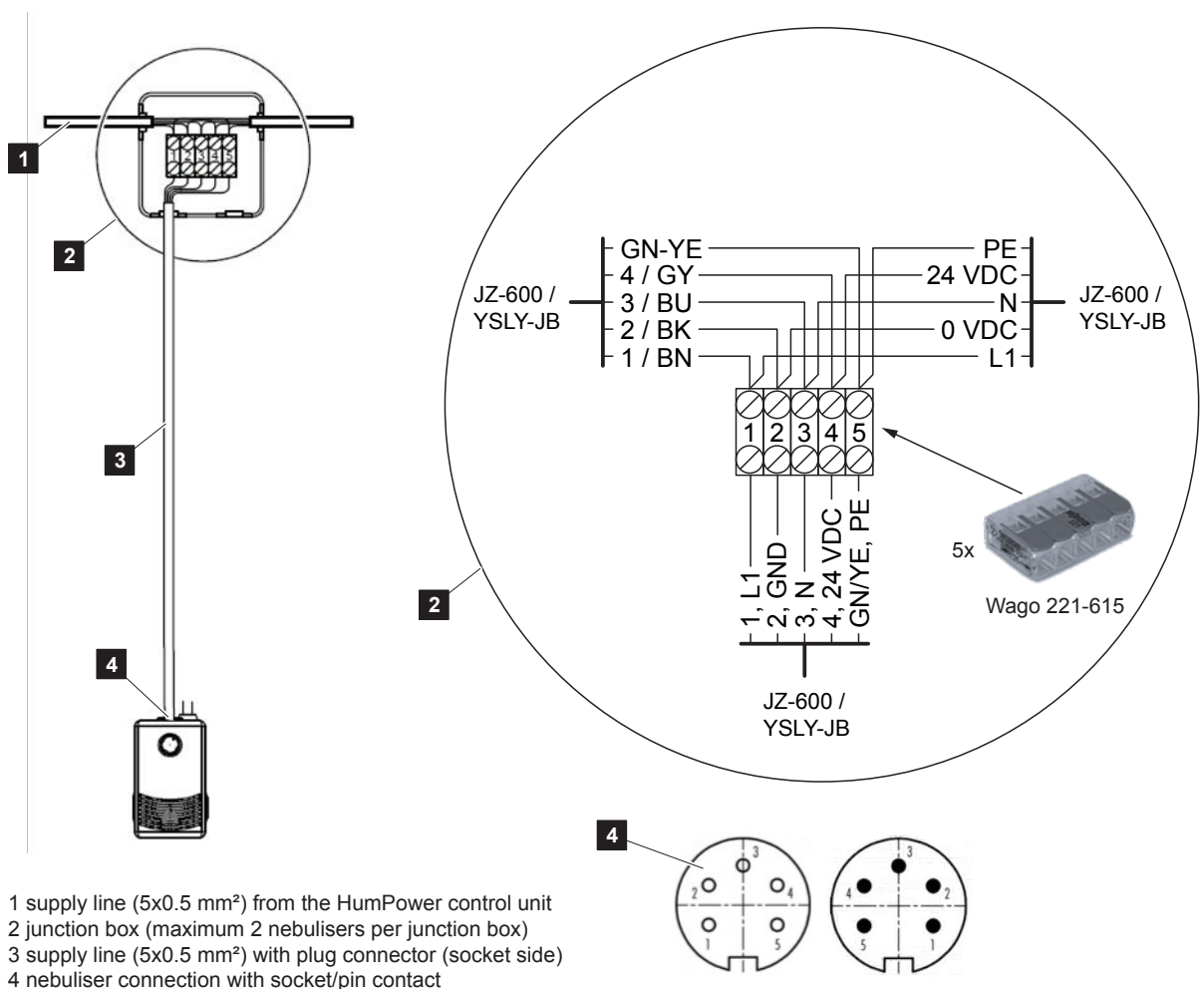

Fig. 23: Connection NanoFogEvolution / NanoFogSens

7.6 Connection DI-Flex / DI-Flex 2

A special connector [6] is included in the delivery of the nebulizer. Only this connector must be used to connect the nebuliser.

The solenoid valves of the nebulizers (DI-Flex / DI-Flex 2) are supplied with 48 V, 50/60 Hz. This voltage is provided by the transformer. As usual, the 230 V, 50/60 Hz in the supply line of the transformer [2] are switched on by the HumPower II if required.

Line [1] H05VV-F 2 x 0,75 mm ²	Line [4] H05VV-F 2 x 2,5 mm ²	Pin assignment [6] plug/socket	Description / function
1 / Brown (BN)	–	–	Phase L1 (230 VAC)
2 / Blue (BU)	–	–	Neutral conductor N (230 VAC)
–	1 / Blue (BU)	1	0V (48 VAC)
–	2 / Black (BK)	2	48 VAC

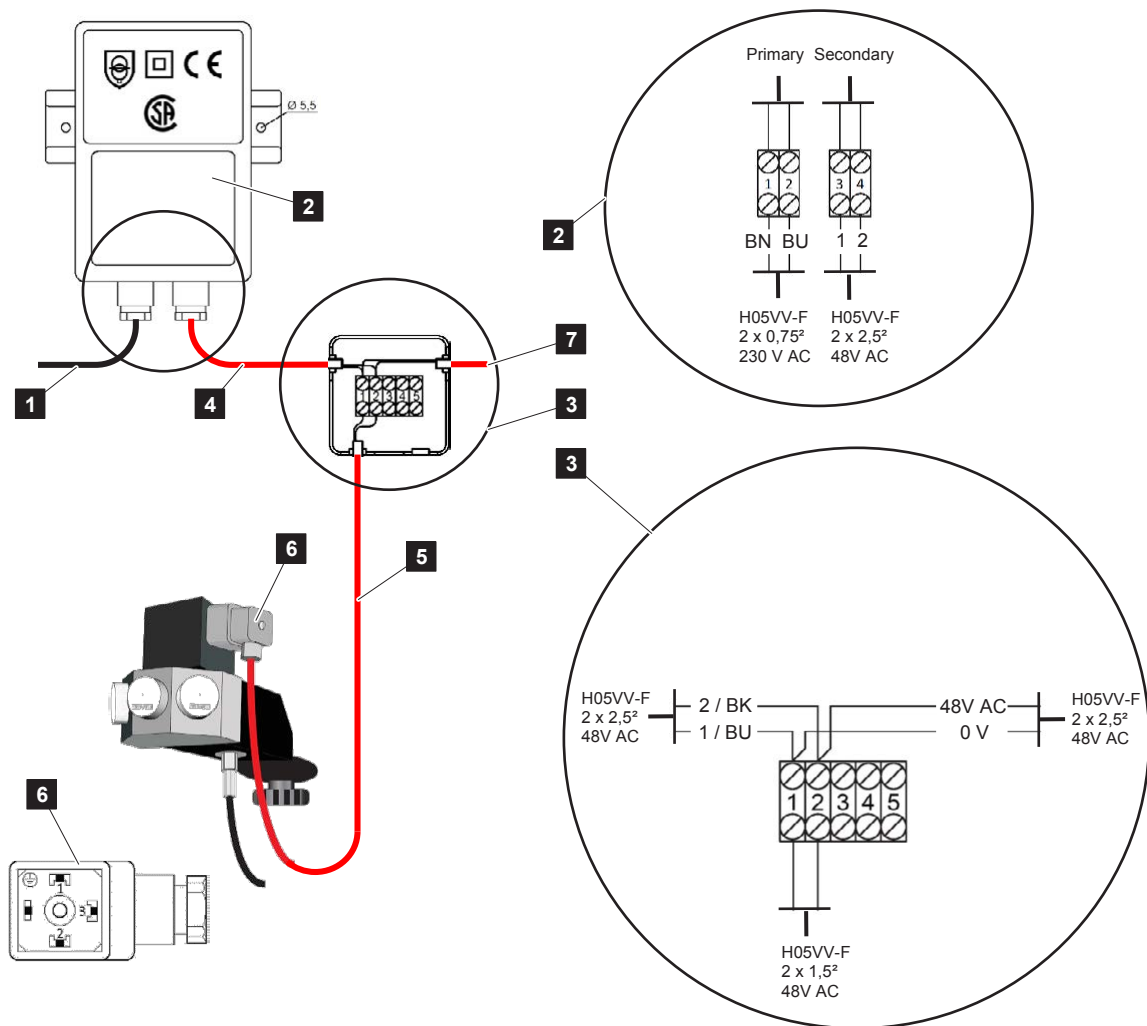

- 1 supply line (2x0.75 mm²) from the HumPower control unit
- 2 transformer 230/48 V, 50/60 Hz, 75W (max 1 pc / HumPower II)
- 3 junction box (maximum 2 nebulizers per junction box)
- 4 control line (2x2,5 mm²) to junction box or DI-Flex
- 5 supply line (2x1.5 mm²) with socket connector (maximum 4 m)
- 6 socket connector DI-Flex
- 7 control line to (further) nebulizers, max. 7 pcs. per transformer

Fig. 24: Connection DI-Flex / DI-Flex 2

8 Maintenance

If abnormalities or malfunctions are detected during checks, Condair Customer Service must be informed immediately. Checks must only be carried out by trained personnel. The operator is responsible for checking the suitability and training of personnel.

For hygiene reasons, we recommend disinfecting the entire water supply network every two years. Condair offers various maintenance plans which have many advantages for operators, including disinfection.



DANGER! **Risk of electrocution**

The DRAABE nebulizers work with mains voltage. (230V AC, 50Hz or 120V AC, 60Hz)

For this reason: Before starting work on the equipment, make sure that the control unit (HumPower II) is disconnected from the power supply (switch off the fuse and secure it against being switched on again and ensure that it is de-energized).



DANGER! **Water under high pressure**

The system may stop under pressure (85 bar) and must be relieved before starting work. Shutting down or switching off the system is described in [Section 8 of the installation and operation manual](#) for the respective high-pressure system (HighPur, DuoPur, TrePur).

8.1 Check

In the case of the nebulizers, the aerosol mist or the nebulization result should be checked at the latest in a cycle of two weeks.

Occasionally, check that all nozzles ((on each nebulizer) are nebulizing.

Also check that there is no puddle formation under the equipment.



NOTE! **Regular checks**

This check every two weeks is important, as identifying a very poor nebulizer output in good time prevents damage in advance. The worse the nebulizer output, the larger the droplets. Falling droplets may indicate corrosion damage, for example.

8.2 Maintenance

Areas with significant dust and/or dirt build-up can block the ventilators and impede the nebulizer's function. This should be checked and the pollution should be removed where necessary.



CAUTION! Cleaning

Do not clean with water or cleaning products of any kind. Use a damp cloth or a brush for cleaning.

8.3 Replacement of nozzles

To replace a high-pressure nozzle, first ensure that the high-pressure system has been switched off and that the high-pressure line has been relieved. Also make sure that the power supply to the control unit has been disconnected, if you disconnect the device from the supply line.



CAUTION! Risk of damage

When replacing the nozzle, avoid contact with the filter insert and nozzle opening. These could possibly be damaged during contact.

Replacement procedure

- Unscrew the nozzles from the atomizer using the supplied nozzle wrench.
- Have a bucket ready to catch the escaping water.
- Screw in the new nozzles. Only use the nozzle wrench supplied for this purpose. Ensure that the nozzle is inserted with the seal!
- Restart the system and check the spray pattern.



NOTE! Returning used nozzles

The used nozzles must be returned to the Condair sales partner in the packaging of the nozzle set.

8.4 Replacing the nebulizers

To replace a complete nebulizer set, first ensure that the high-pressure system has been switched off and that the high-pressure line has been relieved. Also make sure that the power supply to the control unit has been disconnected.

Replacement procedure

- Disconnect the hydraulic supply line via the quick coupling.

Note: Older DI-Flex devices (type designation without the suffix"-MK") do not have a quick coupling installed. Here the high-pressure hose must be separated directly on the device with the hexagonal screw connection. Furthermore, this connection is not self-closing and water leakage can therefore occur.

If a newer DI-Flex device with quick coupling is already installed, first disconnect the quick coupling and then the connection on the device. Keep the quick coupling connector in a hygienic place and reuse it when you mount the replacement device.

- Disconnect the electrical supply line via the quick coupling.
- Loosen the connections to the bracket.
- Fasten the replacement device in reverse order, making sure that no water has got into the electrical connection.
- Restart the system and check the spray pattern.



NOTE!

Air in the stub / droplets at cut-off point

On **commissioning** the replacement device, it must be ensured that the nebulizer can be shut down without droplet formation only after switching on and off multiple times (using the set point adjuster) or after several hours. Protect or cover goods and/or devices where necessary.

This is due to air in the replacement device's high-pressure system. As soon as the air has been flushed out, drip-free switch-off must take place and the device switches off permanently without dripping.



CAUTION!

Leakage check

Once the system is back in operation, look out for any leakages. Check the system occasionally over the next two days.

9 Troubleshooting

9.1 Error list



NOTE!
Troubleshooting

The troubleshooting work highlighted in grey in the table may only be carried out by a Condair service technician or authorized specialist personnel.

If the problem persists, contact your sales partner.

Fault pattern	Possible cause	Remedy
Nozzles drip	Air in the (stub) line or system.	As a rule, the zone is switched on by the system when the target value for the measured air humidity is fallen short of. Perform a high pressure ring flush. Increase or lower the target value cyclically (1 minute operation, 1 minute pause) until the fault pattern clears. or Cycle the zone on and off.
	Only for systems with DI water: conductance in the (random) line too low.	Perform a high pressure ring flush. Increase or lower the target value cyclically (1 minute operation, 1 minute pause) until the fault pattern has been resolved. or Cycle the zone on and off.
	Only for systems with DI water: SynPur system malfunctioning.	Check the gas pressure on the SynPur system. This must be at 6 bar. Check whether errors are reported via the SynPur system.
Poor spray pattern	Nozzle filter clogged.	Replace the nozzle as described in Section 9.3.
	Fan or fan openings dirty.	If necessary, clean the fan as described in Section 8.3 . Replace the device if necessary (see Section 8.4).
	Nozzles dirty.	Replace the nozzle as described in Section 8.3 .

Fault pattern	Possible cause	Remedy
No nebulization takes place	Target value limit exceeded or missing actuation signal	Wait until the target value limit is reached to switch on or increase the target value until the unit turns on
	Maximum humidistat triggered.	Check whether the maximum humidistat is triggered. If necessary, increase the set limit for commissioning up to 100% and reset it to the previously set value after commissioning.
	No high pressure built up in the ring.	Brief interruptions (~15 minutes) may occur during a hygiene rinse or during pure water production. Wait for this time and check the error messages on the system where applicable.
	Check for power supply failure.	Check the building-side fuse protection of the HumPower control unit. Check error messages on the system where applicable.
	Overcurrent fuse in HumPower control unit tripped.	Replace the fine-wire fuse (1.5A, slow blow) in the unit
Tripping of the FI switch/over-current protection	Earth fault or short circuit.	Check if another device on the same connector causes the same error. Return the defective device.
		Service unit and perform electrical safety check.
Heavy dust formation	Only for systems with DI water: SynPur system malfunctioning.	Check whether the SynPur system reports an error and replace the DI levels if necessary
Odor formation	Zone switched off or out of operation for too long.	Disconnect the hydraulic connections to the affected nebulizer and contact your sales partner. The entire system must be disinfected.

10 Technical data

10.1 Technical data TurboFogNeo 1, 2, 2x1 and 2x2 nebulizer

Designation	TurboFogNeo 1	TurboFogNeo 2	TurboFogNeo 2x1	TurboFogNeo 2x2
Max. Output [kg/h] ¹⁾	4,0	8,0	8,0	16,0
Operating pressure [bar] (min; typical; max)	50; 85; 110			
Droplet size [µm] (Sauter) ¹⁾	< 15			
Cleanroom class (ISO 14644-1) ^{1) 2)}	7,8,9			
Dimensions [mm]	142 x 211 x 68		372 x 211 x 68	
Weight [kg]	1,0	1,1	2,2	2,4
Operating voltage [V] (AC)	230 VAC, 50-60 Hz; ± 10%			
Operating voltage [V] (DC)	24 VDC			
Power consumption [W] (AC)	4		8	
Power consumption [W] (DC)	1,73		3.46	
Overvoltage category	II			
Protection class	I			
IP protection type	20			
Use	Only in rooms			
Height above sea level [m]	2,000			
Ambient temperature [°C]	7-35			
Ambient humidity [%rH]	Max. 95%, prevent condensation			
Sound power level [dB(A)] ³⁾	42,9	43,7	42,9	43,7

¹⁾ Depends on nozzle used

²⁾ Only for operation with deionized water or synthesis connection

³⁾ A-weighted sound power level measured at 1 meter.

Note: The sound pressure levels are far below the recommendation (< 55db(A)) of VDI 2058-3 for rooms for mainly intellectual activities.

10.2 Technical data NanoFogEvolution/Sens nebulizer

Designation	NanoFogEvolution	NanoFogSens
Max. Output [kg/h] ¹⁾	1,6	1,2
Operating pressure [bar] (min; typical; max)	50; 85; 110	
Droplet size [µm] (Sauter) ¹⁾	< 15	
Cleanroom class (ISO 14644-1) ^{1) 2)}	7,8,9	
Dimensions [mm]	60 x 100 x 150	
Weight [kg]	0,6	
Operating voltage [V] (AC)	230 VAC, 50-60 Hz; ± 10%	
Operating voltage [V] (DC)	24 VDC	
Power consumption [W] (AC)	4	
Power consumption [W] (DC)	0,72	
Overvoltage category	II	
Protection class	I	
IP protection type	20	
Use	Only in rooms	
Height above sea level [m]	2.000	
Ambient temperature [°C]	7-35	
Ambient humidity [%rH]	Max. 95%, prevent condensation	
Sound power level [dB(A)] ³⁾	40,7	38,9

¹⁾ Depends on nozzle used

²⁾ Only for operation with deionized water or synthesis connection

³⁾ A-weighted sound power level measured at 1 meter.

Note: The sound pressure levels are far below the recommendation (< 55db(A)) of VDI 2058-3 for rooms for mainly intellectual activities.

10.3 Technical data TurboFogNeo 8 nebulizer

Designation	TurboFogNeo 8
Max. Output [kg/h] ¹⁾	32.0
Operating pressure [bar] (min; typical; max)	50; 85; 110
Droplet size [µm] (Sauter) ¹⁾	< 15
Cleanroom class (ISO 14644-1) ^{1) 2)}	7,8,9
Dimensions [mm]	500 x 500 x 64
Weight [kg]	8.0
Operating voltage [V] (AC)	230 VAC, 50-60 Hz; ± 10% (34 W)
Power consumption [W] (AC)	36
Overvoltage category	II
Protection class	I
IP protection type	20
Use	Only in rooms
Height above sea level [m]	2.000
Ambient temperature [°C]	7-35
Ambient humidity [%rH]	Max. 95%, prevent condensation

¹⁾ Depends on nozzle used

²⁾ Only for operation with deionized water or synthesis connection

10.4 Technical data DI Flex / DI Flex 2 nebulizer

Designation	DI Flex M – MK	DI Flex L – MK	DI Flex 2 M – MK	DI Flex 2 L – MK
Max. Output [kg/h] ¹⁾	3,2	8,0	4,8	12,0
Operating pressure [bar] (min; typical; max)	50; 85; 110			
Droplet size [µm] (Sauter) ¹⁾	-		< 15	
Clean room class (ISO 14644-1) ^{1) 2)}	-		7,8,9	
Dimensions [mm]	142 x 211 x 68		372 x 211 x 68	
Weight [kg]	1	1,1	2,2	2,4
Operating voltage [V] (AC)	48 VAC, 50-60 Hz			
Power consumption [W] (AC)	10			
Overvoltage category	I			
Protection class	III			
IP protection type	20			
Use	Only in rooms			
Height above sea level [m]	2.000			
Ambient temperature [°C]	7-35			
Ambient humidity [%rH]	Max. 95%, prevent condensation			
Sound power level [dB(A)] ³⁾	< 42,9 (no fan)			

¹⁾ Depends on nozzle used

²⁾ Only for operation with deionized water or synthesis connection

³⁾ A-weighted sound power level measured at 1 meter.

Note: The sound pressure levels are far below the recommendation (< 55db(A)) of VDI 2058-3 for rooms for mainly intellectual activities.

10.5 Technical data HumPower II control unit

Designation	HumPower II
Dimensions [mm]	180 x 150 x 60
Input voltage range [V] (AC)	120 -240 VAC, 1~, 50/60 Hz
Input voltage range [V] (DC)	25-42 V (via CAN-Bus)
Power consumption [W] (AC)	30
Output voltage [V] (AC)	120-240 VAC, 50/60 Hz (corresponds to input voltage range)
Output voltage [V] (DC)	24
Output power / switching power [W] (AC)	80
Output power / switching power [W] (DC)	20
Overvoltage category	III
Protection class	I
IP protection type	IP66
Use	Only in rooms
Height above sea level [m]	2.000
Ambient temperature [°C]	7-35
Ambient humidity [%rH]	Max. 80 %, prevent condensation

10.6 Technical data transformer

Designation (Type)	Single-phase safety transformer (99-1299)
Dimensions [mm]	180 x 130 x 88
Weight [kg]	3,5
Primary voltage [V]	230 V, 50-60Hz
Primary current [A]	0,34
Secondary voltage [V]	48 V, 50-60 Hz
Secondary current [A]	1,56
Output power / switching power [W]	75
Switching group	II0
Insulation material class	T40/E
Overvoltage category	III
Protection class	II
IP protection type	IP65
Use	Only in rooms
Height above sea level [m]	2.000
Ambient temperature [°C]	7-35
Ambient humidity [%rH]	Max. 80 %, prevent condensation

11 Electrical cable specifications

11.1 Connection cable for nebulizers

Designation	JZ-600 5x 0.5 mm² (with protective earth green/yellow)
Intended use	For voltage supply and signal transmission between: DRAABE Hum-Power II and the nebulizer (junction box)
Peak operating voltage	1 kV
Minimum bend radius	4x DA
Test voltage	4 kV
Temperature range	Fixed installation: -20°C to 70°C Mobile installation: -5°C to 70°C
Ambient humidity	Max. 95 %rH, prevent condensation

Designation	YSLY-JB 5x 0.5 mm² (with protective earth green/yellow)
Intended use	For voltage supply and signal transmission between: DRAABE Hum-Power II and the nebulizer (junction box)
Peak operating voltage	0.5 kV
Minimum bend radius	Fixed installation: 4x DA Mobile installation: 15x DA
Test voltage	4 kV
Temperature range	Fixed installation: -40°C to 70°C Mobile installation: +5°C to 70°C
Ambient humidity [%rH]	Max. 95 %rH, prevent condensation

11.2 Anschlusskabel für Transformator

Designation	H05VV-F 2 x 0,75 mm²
Intended use	For voltage supply and signal transmission between: DRAABE Hum-Power II and the transformer
Peak operating voltage	0.5 kV
Minimum bend radius	Fixed installation: 4x DA Mobile installation: 15x DA
Test voltage	2 kV
Temperature range	Fixed installation: max. 50°C
Ambient humidity	Max. 95 %rH, prevent condensation

12 Appendix

12.1 h,x-diagram

$$\text{Humidification deficit} = X_2 - X_1 = 8,3 \text{ g/kg}$$

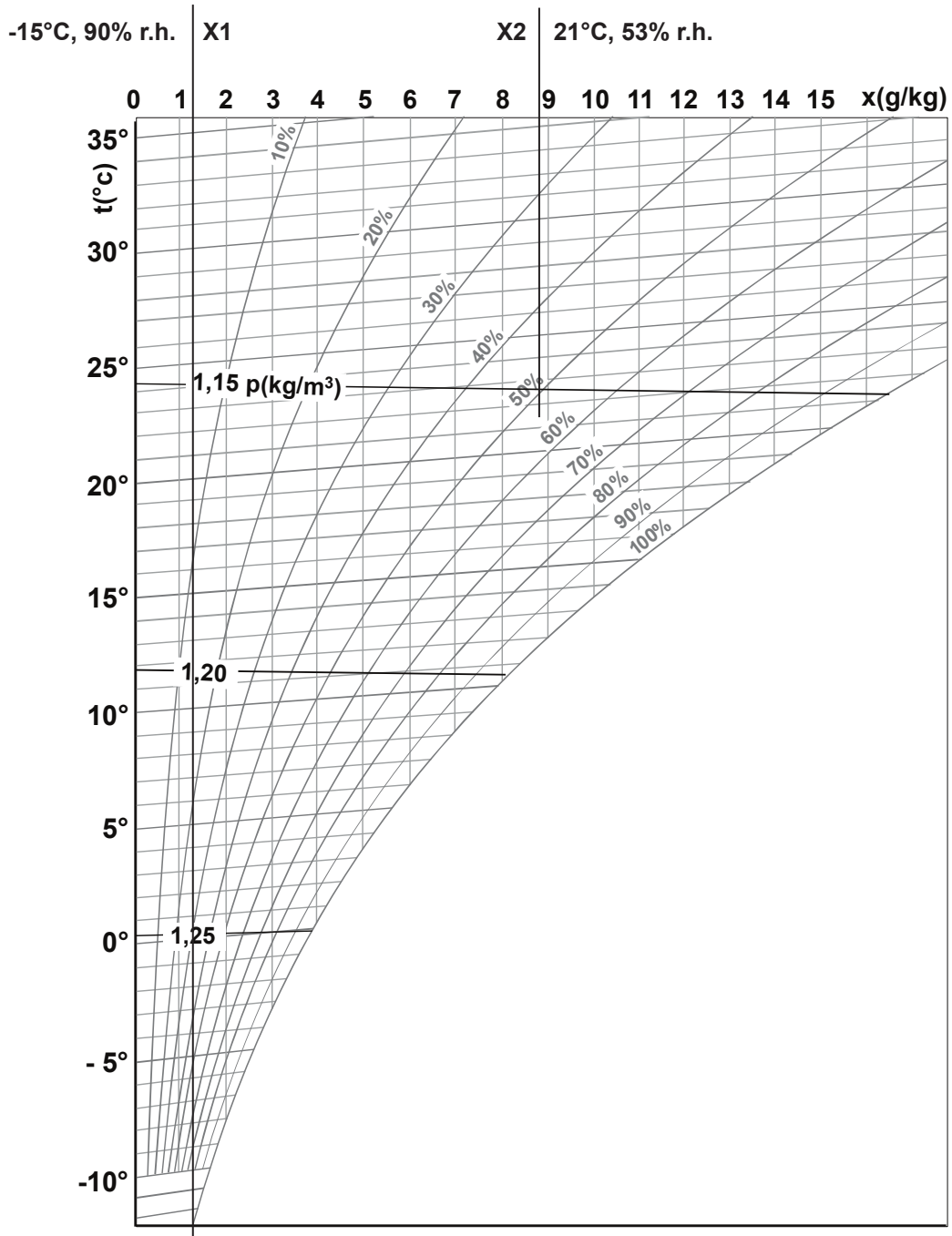

Fig. 25: h,x-diagram with example

12.2 Fresenius inspection certificate

Prüfbescheinigung

Prüfobjekte:

Produktbezeichnung: Luftbefeuchtungsanlage
Typ: PUR

Geprüfte Geräte:

DRAABE Reinwassersystem PerPur, SynPur
DRAABE Hochdrucksystem HighPur
DRAABE Luftbefeuchtungssystem Turbo Fog (TF4, TF16, TF32)
DI Flex (ED/HT), BS

Prüfzeitraum:

Die unter „Geprüfte Geräte“ aufgeführten DRAABE Geräte wurden von uns im Jahre 2005 über einen Zeitraum von 6 Monaten mikrobiologisch geprüft. Es wurden in regelmäßigen Abständen an dem System mikrobiologische Kontrolluntersuchungen durchgeführt, um das Ergebnis auch langfristig zu bestätigen.

Prüfbedingungen und Anforderungen:

Im Rahmen dieser Untersuchung muss die Anlage ihre dauerhaft hygienische Funktion beweisen. Dabei gehen die Prüfbedingungen "vom schlimmsten Fall" (worst case) aus. Dies ist der Fall, wenn:

- die gesamte Anlage sich im stand-by Betrieb befindet
- keine Luftbefeuchtung angefordert wird
- die Raumluft keine Konditionierung hinsichtlich der Feuchte (% rF) benötigt

Die Hygienestufen müssen, während des gesamten Prüfzeitraums (3% Befeuchtung EIN), für die Aufrechterhaltung der nachfolgenden Anforderungen sorgen. Nicht eingesetzt wurden Verfahren, welche einen zusätzlichen Austrag von Chemikalien/Bioziden in der Raumluft zur Folge haben.

Die Anlage wurde im Verlauf der Prüfung 3mal mit einem Keimgemisch kontaminiert. Die Anlagenkonfiguration entsprach der maximalen Ausbaustufe des DRAABE Systems (siehe oben). Das Ergebnis wird durch einen detaillierten Analysenbericht ausgewiesen.

Inhalte Analysenbericht:

Untersuchte Materialien, Versuchsbeschreibung, Testkeime, Kontaminierungsintervall, Keimbelastung, Einzelergebnisse, Zusammensetzung und Menge des Keimgemisches (zur Kontaminierung).

Ergebnis:

Das von uns geprüfte DRAABE System erfüllte die oben angegebenen Anforderungen vollständig. Diesbezüglich sind die Voraussetzungen zur Erteilung eines INSTITUT FRESENIUS Gütesiegels erfüllt. Das geprüfte DRAABE System arbeitet hygienisch einwandfrei und erfüllt die derzeitigen Forderungen (Stand: Dezember 2005) der BG Druck und Papierverarbeitung, Wiesbaden.

Folgende Gesamtkeimzahlen wurden nicht überschritten:

Zulaufwasser Luftbefeuchtung 150 KBE/ml
Befeuchterwasser 150 KBE/ml

Die Beurteilung des Testergebnisses beruht auf den Daten einer nach den von DRAABE erstellten Betriebsvorschriften und Wartungsintervallen betriebenen Anlage.

Taunusstein, Mai 2011

SGS INSTITUT FRESENIUS GmbH

i.V. Dr. Ansgar Ferner

i.A. Franz-Josef Schäfer



Prüfbericht
Auftrag Nr. 479652
Kunden Nr. 5464400

Dr. Ansgar Ferner/Th
Tel. +49 6128/744-266, Fax -203
ansgar.ferner@institut-fresenius.de

Consumer Testing Services
Meat & Food-Managementsystems

SGS INSTITUT FRESENIUS GmbH
Im Maisel 14
65232 Taunusstein

12.3 CE Declaration of Conformity



EC

Konformitätserklärung

Declaration of conformity

Déclaration de conformité

Wir,
Condair Group AG
CH-8808 Pfäffikon SZ
erklären in alleiniger Verantwortung,
dass das Produkt

We,
Condair Group AG
CH-8808 Pfäffikon SZ
declare under our sole responsibility, that
the product

Nous,
Condair Group AG
CH-8808 Pfäffikon SZ
déclarons sous notre seule
responsabilité, que le produit

**DRAABE HighPur
DRAABE SynPur
DRAABE PerPur
DRAABE TurboFogNeo
DRAABE NanoFog**

**HighPur Control
SynPur Control
PerPur Control**

auf das sich diese Erklärung bezieht,
mit den folgenden Normen oder
normativen Dokumenten
übereinstimmt

to which this declaration relates is in
conformity with the following standards or
other normative standards

auquel se réfère cette déclaration est
conforme aux normes ou autres
documents normatifs

**EN 60204-1
EN 13849-1
EN 61000-6-3**

**EN 61000-4-2
EN 61000-4-3
EN 61000-4-5**

**EN 61000-4-6
EN 61000-4-8
EN 61000-4-11**

und den Bestimmungen der folgenden
Richtlinien entspricht

and is corresponding to the following
provisions of directives

et est conforme aux dispositions des
directives suivantes

**2006 / 42 / EC
2014 / 35 / EU
2014 / 30 / EU**

2591044 DE/EN/FR 1905

Pfäffikon, May 01, 2019

Condair Group AG

Robert Merki
Head of Engineering

Condair Group AG
Gwattstrasse 17
8808 Pfäffikon, Switzerland
Phone +41 55 416 61 11, Fax +41 55 588 00 07
info@condair.com, www.condair-group.com

Notes

CONSULTING, SALES AND SERVICE:



CH94/0002.00

Condair Group AG
Gwattstrasse 17, 8808 Pfäffikon SZ, Switzerland
Phone +41 55 416 61 11, Fax +41 55 588 00 07
info@condair.com, www.condairgroup.com

The Condair logo, consisting of a stylized wave symbol followed by the word 'condair' in a bold, lowercase, sans-serif font.